



INDY NXT by FIRESTONE

OFFICIAL RULEBOOK

TABLE OF CONTENTS

1. GENERAL	6
1.1. GOVERNANCE	6
1.2. ASSUMPTION OF RISK, LIABILITY RELEASE, ACKNOWLEDGMENT AND INDEMNITY	7
1.3. CONDUCT IDENTIFICATION	7
1.4. LITIGATION	7
1.5. SECURITY	7
1.6. DATA SHARING POLICY	8
2. MEMBERSHIP	9
2.1. GENERAL	9
2.2. APPLICATION	9
2.3. CATEGORIES	9
2.4. AGE	9
2.5. PHYSICAL AND PSYCHOLOGICAL FITNESS	9
2.6. MEDICAL EXAMINATIONS AND TREATMENT	10
2.7. DETERMINATION OF FITNESS	10
2.8. WAIVER OF CLAIMS	10
2.9. PENALTIES	10
2.10. VIOLATION OF LAWS	10
2.11. MEDICAL RECORDS	10
2.12. EVENT ACTIVITIES	10
2.13. MEMBERSHIPS, LICENSES AND CREDENTIALS	11
3. SANCTIONS	12
3.1. PROMOTION OF RACES	12
3.2. EVENT PROMOTER RESPONSIBILITIES	12
4. ENTRANTS/DRIVERS	13
4.1. GENERAL – ENTRANT LICENSING/DRIVER LICENSING	13
4.2. ENTRANT LICENSE	13
4.3. DRIVER	13
5. ENTRIES	15
5.1. GENERAL	15
5.2. ENTRANT	15
5.3. CAR	15
5.4. CHIEF MECHANIC	16
5.5. SPOTTERS	16
5.6. FEES	17
5.7. DEADLINE	17
5.8. ELECTRONIC ENTRIES	17
5.9. REOPENING OF ENTRIES	17
5.10. FAILURE TO PARTICIPATE	17
5.11. ENTRY CHANGE	17
6. TESTING	18
6.1. GENERAL	18
6.2. EFFECTIVE DATES	18
6.3. TESTING BLACKOUT PERIODS	18
6.4. APPLICATION AND REPORTING PROCESS	18
6.5. TEST PARTICIPANTS	18
6.6. APPROVED TESTING	18
6.7. TIRES	19
6.8. LOCATIONS	19
6.9. ADDITIONAL TESTING LIMITATIONS	19
6.10. VIOLATIONS	19
7. AT TRACK PROCEDURES	20
7.1. ON-TRACK CONDITIONS	20

7.2. FLAG CODES AND/OR TRACK CONDITION LIGHTS (COLLECTIVELY, "FLAGS").....	22
7.3. TIMING AND SCORING.....	23
7.4. COMMUNICATION.....	24
7.5. PIT BOXES.....	25
7.6. RACE START.....	25
7.7. RACE RESTART.....	25
7.8. MECHANICAL CONDITIONS.....	26
7.9. PERFORMANCE STANDARDS.....	26
7.10. PIT PROCEDURES.....	27
7.11. PIT SAFETY VIOLATIONS.....	27
8. QUALIFICATIONS.....	28
8.1. GENERAL.....	28
8.2. OVAL EVENTS.....	29
8.3. ROAD/STREET COURSES.....	30
8.4. QUALIFICATIONS IMPOUND – AT SELECT EVENTS, INDYCAR MAY IMPOSE MANDATORY QUALIFICATIONS IMPOUND PROCEDURES PER THE FOLLOWING.....	31
9. PENALTIES.....	33
9.1. GENERAL.....	33
9.2. SCOPE OF PENALTIES.....	33
9.3. ADDITIONAL PROVISIONS AND GUIDELINES.....	34
10. REVIEW.....	37
10.1. INTRODUCTION.....	37
10.2. WHEN IS A REVIEW PERMITTED.....	37
10.3. WHO MAY REQUEST A REVIEW.....	37
10.4. PROCESS TO REQUEST A REVIEW.....	37
10.5. REVIEW PROCESS.....	37
10.6. COMPLIANCE WITH PROCEDURES.....	39
11. APPEALS.....	40
11.1. INTRODUCTION.....	40
11.2. WHEN IS AN APPEAL ALLOWED.....	40
11.3. WHO MAY REQUEST AN APPEAL.....	40
11.4. SUBMISSION OF APPEALS.....	40
11.5. APPEAL PROCESS AND HEARING.....	40
11.6. COMPLIANCE WITH PROCEDURES.....	42
12. CHAMPIONSHIP AND POINTS.....	43
12.1. CHAMPIONSHIPS AND POINT STANDINGS.....	43
12.2. SIGNIFICANCE OF THE CAR NUMBER.....	43
12.3. CREDITING OF POINTS.....	43
12.4. TIES.....	43
12.5. END OF SEASON AWARDS.....	43
12.6. POINTS.....	43
13. COMMERCIAL ACTIVITIES & AWARDS.....	44
13.1. LOGO DISPLAY.....	44
13.2. ADVERTISING.....	44
13.3. TITLE SPONSOR.....	44
13.4. PRODUCT USE.....	44
13.5. MEDIA.....	45
13.6. AWARDS.....	46
14. TECHNICAL SPECIFICATIONS.....	47
14.1. GENERAL.....	47
14.2. TECHNICAL INSPECTION.....	47
14.3. REFERENCE PLANES AND '0' COORDINATES.....	47
14.4. CAR DIMENSIONS.....	48
14.5. WINGS & WICKERS.....	48

14.6. WING DIMENSIONS	49
14.7. UNDERWING	49
14.8. SKIDS	49
14.9. AERODYNAMICS	50
14.10. BODYWORK	50
14.11. CARBON REPAIRS	50
14.12. FASTENERS	51
14.13. INLET SHUTTERS AND EXIT PANELS	51
14.14. RADIATORS/COOLERS	51
14.15. MIRRORS	51
14.16. WINDSCREEN	51
14.17. PEDALS	51
14.18. ELECTRONICS	51
14.19. CAR TRACKING SYSTEM (ICAR)	ERROR! BOOKMARK NOT DEFINED.
14.20. TELEMETRY	53
14.21. TIMING TRANSPONDER	54
14.22. IMPACT RECORDERS	54
14.23. CAMERAS	54
14.24. SUSPENSION	54
14.25. BRAKES AND DUCTS	55
14.26. DAMPERS AND SPRINGS	55
14.27. DRIVESHAFTS & HUBS	55
14.28. 14.29. EMS	ERROR! BOOKMARK NOT DEFINED.
14.29. WHEELS	55
14.30. CAR WEIGHT AND DRIVER EQUIVALENCY WEIGHT	55
14.31. FUEL & FUEL SYSTEM	56
14.32. EXHAUST	56
14.33. CLUTCH ASSEMBLY	56
14.34. HOSES & FITTINGS	57
14.35. GEARBOX & BELLHOUSING	57
14.36. ENGINE	57
14.37. TURBO & WASTEGATES	57
15. TIRES	58
15.1. GENERAL	58
15.2. TIRE ALLOTMENTS	59
15.3. ROAD / STREET COURSE TIRES	59
15.4. REPLACEMENT TIRES	59
16. EQUIPMENT & GARAGES	60
16.1. PIT LANE FIRE EQUIPMENT	60
16.2. EQUIPMENT	60
16.3. GARAGE	60
16.4. COVERS	60
17. SAFETY	61
17.1. GENERAL	61
18. GLOSSARY	65

**INDY NXT by Firestone
RULE BOOK**

PREFACE

INDYCAR is the preeminent sanctioning body of open wheel racing in North America and functions with the purpose to promote the sport of automobile racing. As such, INDYCAR develops safety and competition regulations which are set forth in this book as it applies to INDY NXT by Firestone.

All INDYCAR Members, as well as every other person participating or involved in any way in INDY NXT by Firestone, shall be bound by these Rules, as amended, supplemented or superseded from time to time and shall be responsible for compliance. It is recommended that you read this Rule Book carefully to assure your familiarity with the rules and regulations contained herein.

Further information may be obtained by contacting the INDYCAR offices at 4551 West 16th Street, Indianapolis, IN 46222, Telephone (317) 492-6526, and rules@indycar.com.

1. GENERAL

1.1. Governance

1.1.1. General

- 1.1.1.1. The Rules govern INDY NXT by Firestone and supersede all previous Rules, bulletins and supplementary Rules and regulations, unless otherwise indicated. Capitalized terms used in the Rules have the meanings set forth in Rule 19, Glossary.
- 1.1.1.2. If the Rules do not expressly permit a variation, then the Member shall presume that such variation is not permitted. If a Member is uncertain if an act and/or part violates a Rule, the burden is on the Member to receive pre-approval in writing from INDYCAR. For this purpose, e-mails are not written approval unless otherwise expressly permitted and specified by INDYCAR by bulletin. The Member assumes the risk of noncompliance. It is not necessary for a competitive advantage to be gained to constitute a violation of these Rules.

1.1.2. INDYCAR and INDYCAR Officiating Incorporated Authority

- 1.1.2.1. Except as provided in Rule 1.1.2.1.1., the Rules shall be applied, constructed, and interpreted by INDYCAR, and INDYCAR's application, construction, and interpretation shall be final and binding.
 - 1.1.2.1.1. INDYCAR delegates application, enforcement and interpretation of Sporting, Technical, Safety, and Aero Kit Regulations to INDYCAR Officiating Incorporated (IOI). The preceding, non-exhaustive categories shall not limit IOI's authority to enforce other categories of Rules. Testing shall be applied and interpreted by INDYCAR, with enforcement by IOI. Any reference in the Rules to INDYCAR may include IOI and any reference to IOI may include a reference to INDYCAR, if the context so requires based on the preceding.
- 1.1.2.2. INDYCAR reserves the right to create and/or revise the Rules at any time, including, without limitation, prior to or during an Event. Notices, bulletins, supplementary Rules, regulations, and penalties are effective on the date and time issued, regardless of the date and time when a Member receives actual notice.
- 1.1.2.3. INDYCAR shall have the right to enforce the Rules, including the rights to impose and/or remove penalties for any violation of the Rules. INDYCAR may penalize any Member and/or exclude any Member or equipment from any Event if INDYCAR deems any act, any omission, any condition to be hazardous and/or not meeting the specifications, requirements, spirit, illustrations, and/or intent of, the Rules.
- 1.1.2.4. INDYCAR shall have the right to determine whether or not to make public a notice stating that INDYCAR has penalized any Member and/or rendered a judgment on a review and/or appeal. If published, the notice may include without limitation a description of the penalty or judgment and names of the affected Member(s).
- 1.1.2.5. INDYCAR shall also have the following rights: (i) to authorize and supervise Events of any kind; (ii) to render decisions concerning the Rules and Events; (iii) to grant, approve, refuse, enforce or withdraw Licenses, memberships, and sanctions; (iv) to assign and cancel dates for Events; (v) to appoint and rescind the appointment of Officials; (vi) to establish, interpret and enforce standards of eligibility for participation in Events; and (vii) to do any and all things which, in its judgment, are consistent with the enhancement, safety and/or integrity of the Events. INDYCAR also reserves the right to take whatever action and/or impose whatever penalty it deems necessary to maintain the integrity and safety of INDYCAR, INDY NXT by Firestone, and/or its Events.

1.1.3. Officiating

- 1.1.3.1. INDYCAR will (i) secure necessary timing and scoring and technical equipment; (ii) and record all timing and scoring information and technical information, including the standings of an Event; (iii) control the designated timing and scoring and technical areas; (iv) provide competition information to the Competitors, the Event Promoter and the press; (v) and facilitate the award distributions. INDYCAR shall be the final authority on the content of all official postings. For clarity, all such information and data shall be the sole property of INDYCAR, and all entities and individuals are strictly prohibited from using this information and data without express consent of INDYCAR.
- 1.1.3.2. INDYCAR may without limitation order the completion, postponement, or cancellation of any Event or any portion thereof for any reason. INDYCAR may terminate a Race before its scheduled number of laps or allotted time and in such case, determine the Race results and disposition of the awards and may terminate a Race after one or more Cars have finished. INDYCAR may increase or reduce the scheduled number of laps or allotted time, and/or may declare an Event completed, postponed, terminated or abandoned.
- 1.1.3.3. As soon as practical after the conclusion of an Event, INDYCAR shall prepare a report giving the results of the Event and may identify reviews lodged and any penalty issued.

1.1.4. Acceptance of the Rules

- 1.1.4.1. Every Member who is involved in and/or participates in any way in any Event shall be deemed to have a full awareness and understanding of and to have accepted, the Rules.
- 1.1.4.2. Every Member agrees to follow the direction of INDYCAR with respect to the enforcement and interpretation of these Rules or be subjected to penalties for failure to comply with such directions.
- 1.1.4.3. If an individual/entity is involved in and/or participates in any Event without having properly submitted fully-executed membership/licensing application materials, the individual/entity, by such involvement and/or participation, nevertheless agrees that the individual/entity is subject to all Rules, limitations of liability, indemnification and all statements, releases and obligations appearing in the membership/licensing application materials as if the individual/entity had properly submitted a fully-executed membership/licensing application materials and to the same extent as if such individual/entity were a Member.
- 1.1.4.4. The Rules shall be governed, interpreted and construed in accordance with the laws of the State of Indiana, without regard to its choice of law principles. All actions relating to the Rules shall be brought in state or federal court in Marion County, Indiana. Each Member consents to venue in and jurisdiction of the state or federal courts in Marion County, Indiana and waives any rights to contest such venue and jurisdiction.

1.2. Assumption of Risk, Liability Release, Acknowledgment and Indemnity

1.2.1. ASSUMPTION OF RISK - EVERY MEMBER AGREES TO BE BOUND BY THE RULES AND ASSUMES ALL OF THE RISK OF SUCH MEMBER'S INVOLVEMENT AND/OR PARTICIPATION IN AN EVENT.

1.2.2. LIABILITY RELEASE - RECOGNIZING THAT AUTOMOBILE RACING CAN BE A HAZARDOUS UNDERTAKING, MEMBERS, FOR THEMSELVES, THEIR HEIRS, EXECUTORS, REPRESENTATIVES, SUCCESSORS AND ASSIGNS, AGREE, BY THEIR MEMBERSHIP, THAT THEY RELEASE AND DISCHARGE INDYCAR GROUP FROM ANY AND ALL LIABILITY FOR DAMAGES TO PROPERTY, PERSONAL INJURY, AND/OR DEATH, IN ANY WAY RELATING TO ANY EVENT OR THE MEMBERS' INVOLVEMENT AND/OR PARTICIPATION IN THE EVENT, REGARDLESS OF HOW THE CLAIM MIGHT ARISE INCLUDING WITHOUT LIMITATION RACE OFFICIATING, RULE INTERPRETATION AND VIOLATIONS, PHYSICAL CONDITION OF THE TRACK, AND/OR EMERGENCY TREATMENT OR RESCUE.

1.2.3. ACKNOWLEDGMENT.

1.2.3.1. MEMBERS RECOGNIZE THIS RELEASE APPLIES EVEN IF INDYCAR GROUP OR ANY OF THE INDYCAR GROUP ACTED NEGLIGENTLY AND UNDERSTAND THAT MEMBERS MAY BE ASKED TO ACKNOWLEDGE THIS ASSUMPTION OF RISK AND RELEASE BY OTHER AGREEMENTS THEY MIGHT SIGN AS A PREREQUISITE TO PARTICIPATE IN AN EVENT OR EVENTS.

1.2.3.2. EACH MEMBER ACKNOWLEDGES THAT THE MEMBER HAS MADE THE MEMBER'S SPOUSE, DOMESTIC PARTNER, AND/OR DEPENDENTS AWARE OF THE MEMBER'S DECISION TO ASSUME AND INCUR THE RISK ASSOCIATED WITH RACING WITHOUT THE RIGHT TO PURSUE CLAIMS OF WRONGDOING.

1.2.4. INDEMNITY – EACH MEMBER ACKNOWLEDGES THAT MEMBER IS RESPONSIBLE FOR VIOLATION OF MEMBER'S AGREEMENTS BY MEMBER, MEMBER'S REPRESENTATIVES INCLUDING LOVED ONES AFFECTED BY MEMBER'S INVOLVEMENT AND/OR PARTICIPATION, AND MEMBER'S PARTICIPANTS AND GUESTS. THIS RESPONSIBILITY APPLIES TO ALL VIOLATIONS OF MEMBER'S AGREEMENTS WITH INDYCAR. THIS INCLUDES THE MISUSE OF CREDENTIALS AND THE FAILURE TO ACCEPT THE ASSUMPTION OF RISK, THE WAIVER AND RELEASE OF LIABILITY, THE BINDING NATURE OF THE RULES, INDYCAR'S INTERPRETATION OF THE RULES, AND THE FINALITY OF THE APPEAL PROCEDURE. MEMBER UNDERSTANDS THAT THIS RESPONSIBILITY INCLUDES THE DUTY TO INDEMNIFY AND HOLD INDYCAR GROUP HARMLESS FROM THE CONSEQUENCES AND DAMAGES ARISING FROM THE VIOLATION.

1.2.5. INDYCAR may periodically request that a Member acknowledge the release, assumption of risk and indemnification provisions in the membership application materials, but the failure of INDYCAR to request and/or a Member to sign an acknowledgement does not negate the release, assumption of risk and indemnification provisions in the membership application materials or in these Rules.

1.3. Conduct Identification

1.3.1. A Member should never make a claim against INDYCAR or a person or entity connected with INDYCAR that an injury, including a fatal injury, has been caused by wrongful conduct that is intentional or willful and wanton unless the claim can be supported by established facts. Even if factually supportable, such a claim cannot continue unless the notice required in the membership application is timely completed.

1.4. Litigation

1.4.1. Each Member agrees to reimburse INDYCAR Group and other named Members (INDYCAR Member Group) for all costs of litigation including without limitation travel expenses and attorneys' fees, costs and expenses if either of the following conditions occurs:

1.4.1.1. The Member initiates or otherwise causes a member of the INDYCAR Member Group to be named as a party in a legal proceeding not permitted or contemplated by the Rules;

1.4.1.2. The Member requests or compels a member(s) of the INDYCAR Member Group's participation in a manner other than as a party to the lawsuit.

1.5. Security

1.5.1. Only authorized individuals are permitted on the Track and in other restricted locations designated by INDYCAR or an Event Promoter including without limitation spotter stands, marshal's posts, safety truck locations, photographer locations and broadcast platforms.

1.5.2. INDYCAR and the Event Promoter have the right to engage in such searches of individuals and property at any Event, as they deem necessary or appropriate for the safety and security of the Event. If they deem necessary, INDYCAR and the Event Promoter have the right but are not required to remove any individual and/or property from the Event.

1.5.3. INDYCAR may but is not required to penalize any Entrant, Associate, or other Member who's representative or equipment enters a restricted area at any Race Location prior to the scheduled opening time or remains in a restricted area at a Race Location after the scheduled closing time without prior approval from INDYCAR and the Event Promoter.

1.5.4. Only Members possessing a valid Driver's license may operate a motorized vehicle in a restricted area during an Event. Only INDYCAR-approved vehicles are permitted in the pit area. INDYCAR and/or an Event Promoter may have additional or different requirements for a particular Event.

1.5.5. Members must not operate or permit another individual to operate a motorized or non-motorized vehicle at the Race Location negligently, recklessly or without due consideration to Members, spectators or others.

1.5.6. Any Member involved in a crash or injured in an incident must report to the medical center or as directed by INDYCAR before departing the Race Location prior to the conclusion of the Event.

1.5.7. Smoking is not permitted on the Track, in the pit area, or in any fuel service area. INDYCAR and/or an Event Promoter may have additional or different requirements for a particular Event.

1.5.8. The possession of firearms by non-law enforcement personnel during an Event is prohibited.

1.5.9. The use of drones or any other unmanned aircraft systems ("UAS") at an Event is prohibited unless approved in advance in writing by the president of INDYCAR. As a condition of such approval, INDYCAR may require a Member to agree in writing with a policy statement that may include, without limitation: i) compliance with all applicable local, state and federal, rules and regulations; ii) adherence with

INDYCAR-designated standards of use of the drone or UAS; iii) provision of insurance as required by INDYCAR and/or the Event promoter; and iv) completion of all applicable location releases and other agreements regarding the use of any photograph, video, footage, data, and/or other information gathered by the drone or UAS.

1.6. Data Sharing Policy

1.6.1. INDYCAR owns any and all rights to exploit the INDY NXT by Firestone and/or, without limiting the foregoing, the Events, or portions thereof, including without limitation, all photographic, video, audio, films, still and/or motion picture images, sounds and data or other reproductions thereof (e.g., in-car audio, in-car video, in-car radio, other electronic transmissions between cars and crews and timing and scoring information).

1.6.2. INDYCAR may disclose the data to third parties for any purpose including, without limitation, safety and/or medical research.

1.6.3. If an individual desires to receive any such data from INDYCAR, the individual shall submit a request in writing to the president of INDYCAR. The written request shall specify the date requested and the proposed use of the data.

1.6.3.1. INDYCAR shall determine whether to provide the data, taking into account such factors as the nature of the data requested, the uses for which the individual requests the data and whether or not consent and/or approval of any other individual is required or appropriate in order to release the data.

1.6.3.2. The individual requesting the data will be required to execute an agreement regarding approved uses for the data and the confidential treatment of any data that INDYCAR approves for use by the individual.

1.6.4. Notwithstanding the foregoing, an Entrant may record its own pit stop activities from its own pit area during Events for the purpose of internal evaluation. All other activities and/or uses require prior INDYCAR written approval.

1.6.5. INDYCAR owns any and all video footage captured via the AiM camera system. Teams are required to retain all footage recorded by the AiM camera system for a minimum of 30 days.

1.6.5.1. Photography-Videography Policy – All Members must comply with INDYCAR's Photography-Videography Policy which is available from ePaddock.

2. MEMBERSHIP

2.1. General

INDYCAR is a voluntary membership organization. Each Member shall be deemed to be an independent contractor of INDYCAR and the relationship between INDYCAR and a Member shall not be deemed to be a partnership, joint venture, an employment or a franchise relationship by virtue of the membership. Members are responsible for the conduct of Member Group.

2.2. Application

2.2.1. Each applicant is required to submit the following properly executed materials for INDYCAR approval in the form required by INDYCAR:

2.2.1.1. Membership application,

2.2.1.2. Membership application fee,

2.2.1.3. Substance Abuse Policy Authorization for Testing and Release (if the applicant is a designated Competitor or Official),

2.2.1.4. Social Media Policy Acknowledgement (if the applicant is a Competitor or Official),

2.2.1.5. Participant Authorization for Use and Disclosure of Protected Health Information, and

2.2.1.6. Any other materials required by INDYCAR.

2.2.2. Membership criteria shall be determined by INDYCAR and may be periodically revised. Each applicant must be in Good Standing.

2.2.3. Applicants and Members agree INDYCAR may refuse a membership application or revoke a membership for any reason including, without limitation, those related to personal conduct, decency and whether or not any conduct of the applicant or Member creates adverse notoriety with respect to INDYCAR, INDY NXT by Firestone, or an Event.

2.2.4. Each applicant agrees to fulfill all contractual obligations such applicant and/or applicant's affiliates may have to INDYCAR, Event Promoters, Manufacturers and their affiliates. Each applicant agrees that INDYCAR, Event Promoters, Manufacturers and their affiliates shall have the remedy of specific performance with respect to any and all such obligations in addition to all other rights and remedies available at law or in equity and notwithstanding any terms to the contrary in any other agreement.

2.2.5. Each applicant must pay any and all outstanding financial obligations owed by applicant or its affiliates to INDYCAR, Manufacturers and their affiliates, or make other arrangements acceptable to INDYCAR, Manufacturers and their affiliates.

2.2.6. INDYCAR shall determine whether to accept or reject any membership application materials, although the rejection of membership application materials may be reviewed and/or appealed in accordance with the procedures set forth in [Rule 10](#) and [Rule 11](#).

2.2.7. Regardless of where the application material is executed by the applicant and/or accepted by INDYCAR and/or the credential issued, applicant recognizes and agrees that the Member's application materials and associated agreement is an Indiana contract and forms a contractual relationship established in the State of Indiana and governed by the laws of Indiana. This contract and relationship is a legal one and applicant should consult his/her attorney if he/she has any legal questions.

2.3. Categories

2.3.1. The following membership categories exist:

- a) Entrant
- b) Driver
- c) Associate
- d) Official
- e) Media
- f) VIP

2.4. Age

2.4.1. Unless otherwise specified, all applicants who are individuals must be at least eighteen (18) years of age. For example, INDYCAR may require a Competitor to be an age greater than eighteen (18) years of age or require additional and/or different requirements for a particular category and/or Event.

2.4.2. No one under age 18 shall be permitted in Pit Lane during any Events unless permitted by applicable insurance requirements and previously approved in writing by INDYCAR and/or the Event Promoter.

2.4.3. At INDYCAR's discretion, a Driver, age 16 years and 180 days, on-Track activities. All agreements and documentation as to additional obligations as required by INDYCAR must be completed to INDYCAR's satisfaction before the application will be considered. If accepted and for the duration of time that INDYCAR allows, the individual will have all rights of a licensed driver.

2.5. Physical and Psychological Fitness

2.5.1. INDYCAR may require any applicant or Member to complete a medical history form and/or complete and pass a medical examination which may include drug testing consistent with the provisions of the Substance Abuse Policy as directed by INDYCAR to determine physical and psychological fitness to receive a membership or License and/or to participate or continue in an Event. At any time, INDYCAR may require a Member to be examined and/or tested by a designated medical professional at the Member's cost.

2.5.2. Members must not use or be under the influence of illegal or prohibited drugs at any time, alcohol during an Event, and certain prescriptions and over-the-counter medications during an Event. Designated Competitors and Officials must complete and return to INDYCAR the current Substance Abuse Policy Authorization for Testing and Release and must comply with the provisions of the Substance Abuse Policy at all times. Whether or not an applicant or Member has formally executed the INDYCAR Substance Abuse Policy

Authorization for Testing and Release, each applicant and Member agrees to submit to drug testing in accordance with the Substance Abuse Policy, which may include without limitation the collection of urine, blood, saliva, hair, breath and/or any other scientifically-acceptable method of analysis for prohibited substances and/or alcohol if requested by INDYCAR. Examination/testing may be for any drug, medication or other substance including without limitation alcohol. Applicants and Members shall be requested to regularly review the Substance Abuse Policy and will be notified by INDYCAR as changes to the Substance Abuse Policy are made. Changes to the Substance Abuse Policy will apply as they become effective regardless of the actual notice and it is not an acceptable excuse for an applicant or Member to claim that the applicant or Member is unaware of a change to the Substance Abuse Policy or that such a change is not reflected in the Rules for purposes of avoiding the consequences of noncompliance.

2.5.3. Any applicant or Member who is required to complete a medical history form and/or complete and pass a medical examination/test shall also immediately notify in writing the INDYCAR Medical Director if the Member becomes aware of a change in the Member's medical condition, including if the Member is diagnosed with any medical condition (including pregnancy) by any medical professional.

2.5.4. Any Member who is required to execute the Substance Abuse Policy Authorization for Testing and release shall also submit proof of any prescription the Member is required to take to the INDYCAR Medical Review Officer (and receive the INDYCAR Medical Review Officer's approval of such use prior to taking the substance in connection with any Event) (whether or not prescription drugs or medication and regardless of how taken).

2.5.5. INDYCAR may disqualify, suspend or otherwise penalize any applicant or Member for failure to promptly cooperate with any request for examination/testing and/or notification by INDYCAR and for any pending violation of the Substance Abuse Policy.

2.6. Medical Examinations and Treatment

2.6.1. Examinations and/or treatment of Members, including emergency rescue, performed by medical professionals acting on behalf of INDYCAR are based upon a relationship established in the State of Indiana.

2.6.2. Members acknowledge that the medical professionals engaged by INDYCAR are acting pursuant to their contractual obligations with INDYCAR and are not acting or rendering personal medical services to the Members. Members acknowledge that they shall have their own personal physicians.

2.7. Determination of Fitness

Members acknowledge that while the INDYCAR medical professionals render an opinion as to fitness, the final determination of a Member's ability to participate is made by INDYCAR.

2.8. Waiver of Claims

Each applicant and Member waives any and all claims regarding any medical treatment and/or medical examinations/testing and/or examination/testing results, and/or the use or disclosure of such medical treatment and/or medical examinations/testing and/or examination/testing results, by INDYCAR, its agents and/or its medical professionals including without limitation claims of invasion of privacy and/or breach of confidentiality, notwithstanding whether such claims arise from strict liability, sole or contributory negligence of INDYCAR, its agents and/or its medical professionals, breach of contract, or any other legal or equitable theory.

2.9. Penalties

2.9.1. INDYCAR may disqualify, suspend or otherwise penalize any applicant or Member if the results of any examination/test are determined by INDYCAR, its agents and/or its medical professionals to be a violation of the INDYCAR Substance Abuse Policy or to enhance, impair, or otherwise affect the Member's ability to be involved in and/or participate in any Event regardless of whether the applicant or Member's B sample, if applicable, has confirmed the A sample finding, in the case of a drug test. INDYCAR in its discretion may suspend or otherwise penalize any applicant or Member while such applicant or Member's matter, whether it is a positive drug test or other violation of the Substance Abuse Policy or other applicable Rule, is pending or while INDYCAR investigates the applicant or Member's potential Rule violation.

2.9.2. Any Member who shows visible signs of exhaustion, physical or psychological impairment, or other physical or psychological irregularities may be disqualified and/or excluded from an Event and subjected to additional examinations/tests and/or penalties.

2.10. Violation of Laws

Being charged with a violation of the law, whether alcohol/substance abuse or any other laws, may be grounds for suspension or other penalty. Any Member charged with any violation of the law relating to alcoholic beverages or illegal substances, or charged with any felony, must notify the president of INDYCAR prior to the next scheduled Event or within 72 hours of being so charged, whichever is earlier, and cooperate with INDYCAR, including without limitation, providing additional information in order for INDYCAR to determine if a suspension or other penalty is appropriate.

2.11. Medical Records

Each applicant and Member agrees and consents that, where requested by INDYCAR for purposes of carrying out its due diligence and obligations under the Rules and the Substance Abuse Policy, he or she will not unreasonably deny INDYCAR access to and copies of any and all medical records of the Member where access to such information may be necessary in order for INDYCAR to make a determination with respect to the applicant or Member's eligibility for participation in an Event. Applicants and Members acknowledge that denial of access by INDYCAR to such information may delay or prohibit INDYCAR from permitting the applicant or Member to compete and/or participate in Events.

2.12. Event Activities

2.12.1. Activities - INDYCAR may schedule mandatory meetings and/or activities for Members. INDYCAR may require a meeting with Member(s) at any time. Each Member must attend and actively participate in all official meetings and other activities designated by INDYCAR as mandatory for that Member at the times and locations designated by INDYCAR. These may include, but are not limited to the following:

2.12.1.1. Competition Meetings - INDYCAR may conduct one or more meetings of Drivers, team managers, spotters and chief mechanics to discuss general application, construction and interpretation of the Rules and any specific Rules applying to a particular Event. INDYCAR has the right to determine attendees.

2.13. Memberships, Licenses and Credentials

2.13.1. Prior to gaining access to restricted areas, each individual must have the necessary and appropriate credential. The holder of a membership, License or other credential shall produce it for inspection upon demand of INDYCAR or security personnel at any Event along with any other document needed to confirm identification.

2.13.2. The annual credential consists of both the lanyard and the hard card. Use of one without the other invalidates the annual credential. In addition, a Member must not use a prior Event's, prior racing season's or other series' credential.

2.13.3. A membership, License or any other credential (including race mode) may not be disassembled, transferred, assigned, sold, made subject to a lien, altered, or duplicated. It must be used only by the Member to whom it is issued. If a Member intentionally or unintentionally disassembles, transfers, assigns, sells, makes subject to a lien, alters, duplicates or otherwise permits another individual or entity to use or attempt to use the membership, License or credential, then the Member may be penalized and shall indemnify and hold INDYCAR Group harmless from any loss or expense incurred by INDYCAR Group arising in any way from the Member's action, even if the Member or a third party asserts that INDYCAR Group's loss or expense is due to INDYCAR Group's negligence.

2.13.4. The Rules regarding memberships, Licenses and credentials are equally applicable to parking passes, Event credentials, golf cart passes, and all other privileges issued to a Member by INDYCAR or an Event Promoter unless such credentials, passes or privileges are expressly transferable, assignable, or eligible for sale.

2.13.5. INDYCAR may require an applicant and/or Member to provide a valid official government-issued identification including photograph and date of birth in order to receive or retain a credential. Acceptable identification includes without limitation a state driver's licenses, passports and military cards, but does not include identification issued by educational institutions or any nongovernmental entity.

3. SANCTIONS

3.1. Promotion of Races

INDYCAR will sanction Races with an Event Promoter through an Event Agreement. The Event Agreement contains additional terms regarding the Race, such as those relating to postponement dates.

3.2. Event Promoter Responsibilities

3.2.1. Event Promoters shall be responsible for designated operations including for example and without limitation responsibility for obtaining and providing, at the Event Promoter's expense, insurance as required by the Event Agreement, safety precautions, services and vehicles for Competitors and spectators including medical/rescue personnel, equipment, transportation and facilities (such as ambulances, air medical helicopters and examination facilities and equipment); physical condition of the Track; spectator control; and fire protection, all to meet or exceed the minimum requirements provided by INDYCAR and where applicable, the ASN.

3.2.2. INDYCAR shall not be responsible or in any manner liable for any of the Event Promoter's responsibilities under the Event Agreement or the Rules even if the Event Promoter fails or refuses to perform such functions, duties and responsibilities, in whole or in part, or if INDYCAR voluntarily assumes performance of any or all of the Event Promoter's specific functions, duties and responsibilities.

3.2.3. Members acknowledge that INDYCAR has the right to place additional regulations into effect if, in the discretion of INDYCAR and/or an Event Promoter, such additional regulations become desirable.

3.2.4. INDYCAR may require the Event Promoter to use, in compliance with local regulations and/or FIA requirements, medical/rescue personnel and equipment acceptable to INDYCAR to provide Members with assessment and treatment of emergency medical conditions.

4. ENTRANTS/DRIVERS

4.1. General – Entrant Licensing/Driver Licensing

- 4.1.1. Licensing criteria are available from the INDYCAR office and may vary depending on the particular on-Track activity. INDYCAR and ACCUS-FIA (and another ASN, if applicable) shall determine whether to approve a License application and issue a License. Applicant shall pay any and all costs associated with satisfying the License criteria. Driver Licenses are not transferable at any time; Entrant Licenses are not transferable without prior written approval.
- 4.1.2. Licenses are revocable by INDYCAR and ACCUS-FIA at any time and for any reason.
- 4.1.3. Eligibility for a License shall be determined based on such factors as are indicative of the applicant's ability to participate satisfactorily in an Event.
- 4.1.4. Fees may be charged for Licenses. Fees are non-refundable whether or not the License is granted. No fee or any part thereof shall be refunded to a licensee because the licensee ceases to participate in any Event(s) regardless of the reason for such cessation.
- 4.1.5. A License is valid only for the current Racing Season and/or as otherwise restricted. Licenses may be limited to a particular type of Event(s) or for a specified period. Licenses for Rookie Drivers are granted on a temporary basis. Unless otherwise noted, all Licenses shall expire on December 31st of the calendar year during which they were granted.
- 4.1.6. An applicant may request the review and/or appeal of a denial of a Driver or Entrant License and membership application, grade of Driver's License, determination of Rookie Driver status or eligibility for ROP or refresher Test in accordance with the procedures set forth in [Rule 10](#) and [Rule 11](#).
- 4.1.7. INDYCAR may continuously re-evaluate the eligibility and performance of a Driver and/or Entrant to determine if the Driver and/or Entrant shall remain licensed. As part of such evaluation, INDYCAR may consider input from any Official, any Driver and others as INDYCAR determines appropriate and may require a Driver and/or Entrant to participate in Testing under the observation of Officials, Drivers, and/or others.

4.2. Entrant License

- 4.2.1. The individual signing the application materials represents that the individual is authorized to act on behalf of the named Entrant in all matters. Additional corporate representatives may be listed, and the authority of any individual may be limited.
 - 4.2.1.1. If a corporate representative's status changes, INDYCAR may require an individual authorized to act on behalf of the Entrant to submit new application materials for that Entrant for approval. INDYCAR may require an Entrant to submit another Entrant License fee and resubmit any other materials including, without limitation, a Leaders Circle Program Agreement, Entry forms, or any other requirements as determined by INDYCAR.
 - 4.2.1.2. Upon request, INDYCAR must be provided satisfactory information regarding ownership of an Entrant.
- 4.2.2. Eligibility
 - 4.2.2.1. Unless otherwise approved by INDYCAR, Entrant must possess an INDYCAR Entrant's License and Membership and an ACCUS-FIA Entrant's License (including international competition privileges). Entrant must remain in Good Standing at all times.
 - 4.2.2.2. After receipt of the application materials, the Entrant's competitive and business viability will be assessed to determine whether to approve and issue the license. Factors taken into account may include, without limitation:
 - 4.2.2.2.1. Purchase and/or lease agreements with Manufacturers;
 - 4.2.2.2.2. Purchase and/or lease agreement for its shop; and
 - 4.2.2.2.3. Employment or consultancy agreements with key personnel including, without limitation, team manager, engineer, chief mechanic and Driver.
- 4.2.3. Entry - Upon issuance of the Entrant License, the Entrant may submit Entry forms identified by the Car number assigned to that Entrant License. The Entry (Car with Driver) must display the Car number at all times during the Event and all points and awards earned by this Entry will be credited to that Car number unless otherwise determined by INDYCAR. An Entrant intending to compete with multiple Entries at a single Event must obtain an Entrant License with a unique Car number for each Entry or satisfy such other requirements as INDYCAR may prescribe.
- 4.2.4. Manufacturers – The Manufacturers may require an Entrant to enter into lease and/or purchase agreements.

4.3. Driver

- 4.3.1. Each Entry form must list a Driver.
- 4.3.2. Driver License
 - 4.3.2.1. License application materials may be approved, and Licenses issued to individuals determined eligible by INDYCAR to compete in an Event and who otherwise meet the application requirements.
 - 4.3.2.2. INDYCAR and/or ACCUS-FIA (and another ASN, if applicable) shall determine the grade of the License issued to a Driver.

4.3.2.3. In order for a Driver to compete in any Event, the Driver must hold a Driver License and at any time may be required to:

- a) Participate in any INDYCAR required testing;
- b) Provide an updated resume, government-issued identification, and/or certified birth certificate;
- c) Furnish a current clearance acceptable to INDYCAR attesting to the Driver's physical/psychological fitness;
- d) Provide proof of United States residency and an international letter of authorization from the Driver's home country ASN, in the case of Drivers who are not citizens of the United States.

4.3.2.4. Eligibility

4.3.2.4.1. Unless otherwise approved by INDYCAR, Driver must possess an INDYCAR Driver's License and Membership and an ACCUS-FIA Driver's License (including international competition privileges) or another ASN Driver's License, if applicable. Driver must remain in Good Standing at all times.

4.3.2.4.2. Driver eligibility is at the sole discretion of INDYCAR.

4.3.2.4.3. INDYCAR may require the applicant to provide:

4.3.2.4.3.1. A current resume containing a complete history of the applicant's competition to date and demonstrating the applicant's ability to properly and safely handle the Car;

4.3.2.4.3.2. A letter of recommendation from the series in which the Driver last competed; and/or

4.3.2.4.3.3. Such other information as INDYCAR may request.

4.3.2.5. Physical/Psychological Information - The applicant must provide the information required by INDYCAR and must successfully complete any INDYCAR-prescribed physical and psychological examinations, which may include, without limitation, eye, neurological and substance abuse testing.

4.3.2.6. Refresher Tests - An applicant, including, without limitation, a Driver who has not participated as a Driver in any INDY NXT Series on-Track Event during the past six (6) months, may be required to successfully complete a refresher test. In lieu of a refresher test, INDYCAR may require an applicant to successfully complete ROP.

4.3.2.7. Rookie Driver General

4.3.2.7.1. Before a Rookie Driver's participation in his/her first (1st) Oval Event, the Rookie Driver must complete a ROP supervised by INDYCAR.

4.3.2.7.2. The determination of whether the applicant may take ROP and whether the applicant successfully completed ROP shall be made by INDYCAR.

4.3.2.7.3. If a Driver begins the Racing Season as a Rookie Driver, he/she remains a Rookie Driver until the end of that Racing Season.

4.3.2.8. ROP – An applicant must demonstrate Car control, placement and interaction with other Cars on-Track to the satisfaction of INDYCAR. INDYCAR may require additional testing including, without limitation, testing in close proximity to other Cars, before an applicant may be permitted to participate in an Open Test and/or Race.

4.3.3. Provided INDYCAR approves the substitution and the change takes place prior to the parade and pace laps, the original Driver entered for the Race may be substituted by:

4.3.3.1. Oval Events – Another approved Driver who has already participated in practice, or a special session for the current Event.

4.3.3.2. Road / Street Course Events – Any other approved Driver.

5. ENTRIES

5.1. General

5.1.1. All Entry applications shall be completed on forms in the manner required by INDYCAR and shall be subject to the approval of INDYCAR. Entries are not transferable without the prior written approval of INDYCAR.

5.2. Entrant

5.2.1. An approved Entry serves as the authorization to compete in a specific Event or Events(s) on behalf of the specific Entrant to whom the Car number is assigned and acknowledgement of an agreement to the Rules.

5.2.2. If an individual/entity participates in any Event without having properly submitted fully executed Entry form materials, the individual/entity, by such participation, nevertheless agrees that the individual/entity is subject to all Rules and all statements, releases and obligations appearing in the Entry form materials for the Event, as if the individual/entity had properly submitted fully executed Entry form materials.

5.2.3. In recognition of the support of racing fans and efforts and monies expended by sponsors, INDYCAR and Event Promoter in connection with the Events, Entrant, on behalf of Entrant Group, agrees to participate in any and all portions of on-Track Events in which Entrant has submitted and INDYCAR has approved, an Entry. Entrant agrees not to engage alone or with others in tactics which would disrupt or delay the on-Track Events and to cooperate fully with ceremonies preceding, during and following the on-Track Event and to refrain from any conduct which would disrupt or detract from such ceremonies.

5.2.4. Entrant understands and agrees that INDYCAR has the right at any time to withdraw the privileges of participation or otherwise reject, exclude or disqualify any member of Entrant Group, including but not limited to any Car, Driver or other Entrant Participant, if INDYCAR in its discretion determines that rejection, exclusion or disqualification is in the best interest or integrity of INDYCAR, the INDY NXT Series or the promotion of Events. Entrant, Driver and any third party they represent, including without limitation other Entrant Participants, shall have no claim for damages or injunctive relief against INDYCAR, any Event Promoter and/or their representatives by reason of such rejection, exclusion or disqualification.

5.3. Car

5.3.1. Participation of a Car in an Event – In order to participate in an Event, the Car must be properly entered and be designated and explicitly identified by Car number on only one Entry form for that Event. Notwithstanding any prior INDYCAR approval, any Car participating in an Event while in noncompliance with the above requirements may be disqualified and any Competitor who causes such noncompliance may be disqualified and/or otherwise penalized by INDYCAR.

5.3.2. Once an Event has begun, Entrants' Car(s) must remain on the Race Location grounds unless otherwise approved by INDYCAR.

5.3.3. Car Registration

5.3.3.1. Car Names – A Car must have a name that shall be identified on the Entry form. The Entrant represents to INDYCAR that it has the right to use that Car name. The Car name is subject to the approval of INDYCAR and must not exceed 35 characters, including all spaces and punctuation.

5.3.3.2. A Car may compete only in the Events in which the Car is entered. The Entry form must establish the Entrant's right to enter the Car in the Event and include proof of ownership of the Car acceptable to INDYCAR. INDYCAR will use a Car number and Dallara assigned chassis registration number to identify each Car.

5.3.3.3. Car Number – INDYCAR will assign to each Entrant License (not Driver License) a unique Car number. The Car number may consist of a maximum of two digits. Car number 1 will be reserved for the defending Entrant (not Driver) series champion.

5.3.3.3.1. All Car numbers are owned by INDYCAR. An Entrant may be granted the use of a Car number.

5.3.3.3.2. All Entrants desiring a particular Car number must make a written request to INDYCAR. INDYCAR will not guarantee a request will be granted.

5.3.3.3.3. After a Car number is assigned to a particular Entrant License, it will remain with that Entrant License until that Entrant is no longer a Full Season Entrant, provided that Entrant enters a Car and displays the Car number on the Car at each Event. If the Entrant does not enter a Car and/or display the Car number on the Car at an Event, INDYCAR may reassign the Car number.

5.3.3.3.4. All aspects of the Car number including, without limitation, height and width must be approved by INDYCAR prior to use.

5.3.3.3.5. The required Car number locations must be clearly visible as determined by INDYCAR. The required number must be a solid color (up to 10% transparency may be applied for graphics), one (1) inch in thickness, positioned on a solid single colored background and maintain a two (2) inch area around the numbers, free of all other decals, trim, color, advertisement and decorations. The number is not required to be continuous in nature, or a traditional font. Trim color around the number is permitted provided it does not distort the readability and does not apply toward the height or width requirement. See Car Appearance and Branding Illustrations for sizes and locations.

5.3.3.3.5.1. Nose – The minimum height of the numeric digit must be nine (9) inches. A portion of the Car number on the nose must be located on the front shock cover.

5.3.3.3.5.2. Headrest – The Car number must be marked on the rear of the headrest a minimum dimension of 1 inch by 1 inch.

5.3.3.3.5.3. Tub – The Car number and Driver's first and last name must be 1 inch tall each. Letters and numbers must be in Impact font, black or white in color and no trim is permitted. This must be located directly behind the headrest.

5.3.3.3.6. Car Appearance – INDYCAR has the right to control the appearance of Cars to distinguish one Car from another. This may include, without limitation Car color. Cars are required to display significantly different colors. INDYCAR requires different color schemes on any four of the following seven parts:

- a) Mirror housing
- b) Roll hoop cover
- c) Roll hoop camera cover
- d) Front and rear wing end fences
- e) Leading edge of the front wing
- f) Leading edge of the rear wing

5.3.3.3.7. Supplier Branding – Entries must display all required supplier logos per Rule 13.1 and the INDY NXT by Firestone Brand Style Guide - TEAM, which can be accessed at epaddock.indycar.com (see car appearance and branding illustration below).

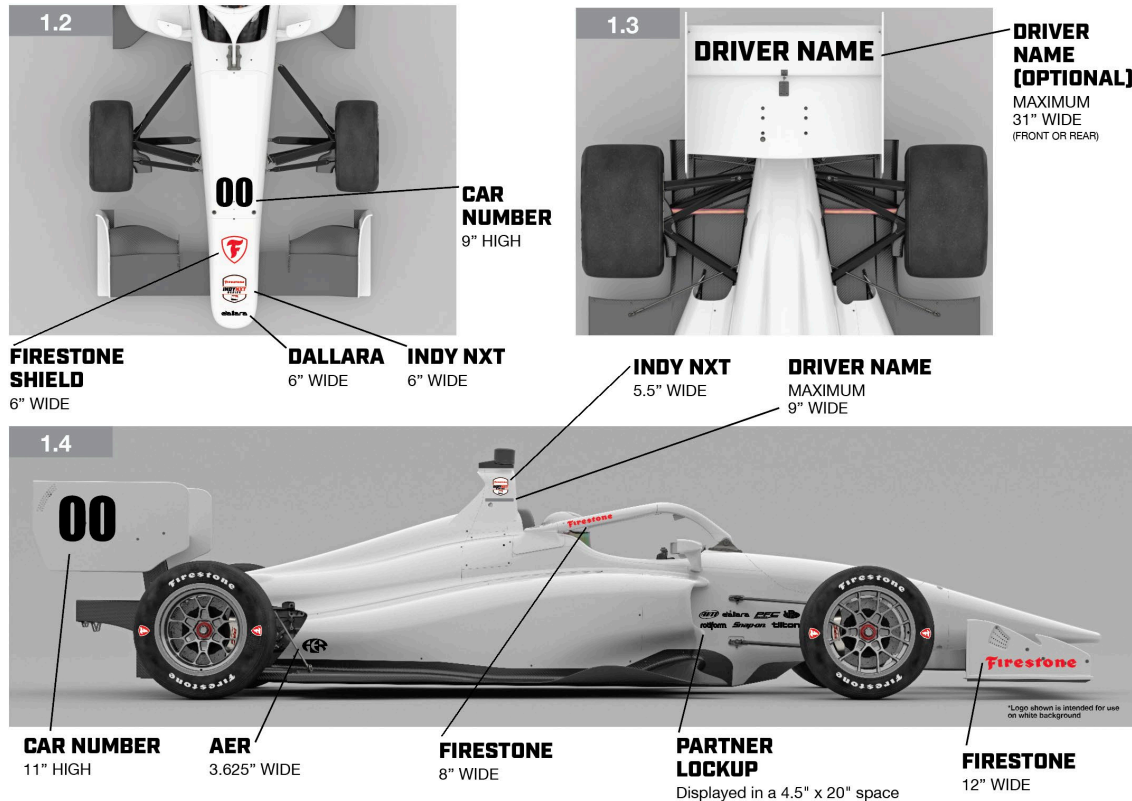

5.4. Chief Mechanic

- 5.4.1. Each Entry must have a chief mechanic.
- 5.4.2. The chief mechanic is responsible for the Car complying with the Rules.
- 5.4.3. The chief mechanic must accompany the Car during all technical inspection processes.
- 5.4.4. Entrant agrees its chief mechanic shall serve as an authorized corporate representative regarding all issues related to technical inspection and communication with INDYCAR.
- 5.4.5. An Entrant shall replace its chief mechanic if INDYCAR determines that the chief mechanic is not sufficiently qualified.

5.5. Spotters

- 5.5.1. Oval Events – One (1) spotter is required during all on-Track activity, excluding Qualifications.
- 5.5.2. A spotter must:
 - 5.5.2.1. be in the INDYCAR-specified location(s),
 - 5.5.2.2. have a radio capable of communicating with the Driver and a Member in the Entrant's Pit Box,
 - 5.5.2.3. monitor the Team Broadcast Frequency,
 - 5.5.2.4. have the required memberships, and
 - 5.5.2.5. be registered with INDYCAR.

5.6. Fees

Entry fees must be paid in good funds as directed by INDYCAR.

5.7. Deadline

The Entry deadline shall be stated on the Entry form. Unless otherwise specified on the Entry form, the hour of closing shall be 5pm E.T. on the day of the Entry deadline. INDYCAR may accept or refuse to accept late Entries. Late Entrants, if accepted, may be penalized by INDYCAR.

5.8. Electronic Entries

An Entry by electronic mail or other means delivered by the closing of the Entry deadline may be accepted, provided it is subsequently accompanied by the Entry fee within 48 hours of INDYCAR's receipt of the Entry or as otherwise directed by INDYCAR.

5.9. Reopening of Entries

If INDYCAR postpones an Event, INDYCAR may authorize the reopening of Entries. Reopened Entries shall close not less than forty-eight (48) hours before the declared starting time of the postponed Event.

5.10. Failure to Participate

Any Driver, Entrant, or other Member who by Entry form or other means has agreed to participate in an Event may be penalized for failing to participate in any portion of such Event.

5.11. Entry Change

All changes to an approved Entry form shall be completed via ePaddock and are subject to approval by INDYCAR prior to the Entrant's Car participating in any on-Track activities.

6. TESTING

6.1. General

6.1.1. All Tests must comply with the Rules.

6.1.2. Costs – The primary renter shall pay all costs incurred by INDYCAR relating to any tests approved by INDYCAR.

6.2. Effective Dates

6.2.1. Rule 6 applies from after the final Race of a given Racing Season through the final Race of the following Racing Season.

6.3. Testing Blackout Periods

6.3.1. Except as otherwise provided in this Rule, on-Track Testing may not occur, or is “blacked out”:

6.3.1.1. For seven (7) days following the final Race Event, and

6.3.1.2. Beginning the Tuesday prior to the Race Event,

6.3.1.3. All days between Race Events occurring in consecutive weeks, and

6.3.1.4. Within one (1) calendar Day of the start of any on-Track activity at any Open Test.

6.3.1.5. During the following periods:

6.3.1.5.1. November 22, 2025 – November 30, 2025 (Thanksgiving), and

6.3.1.5.2. December 13, 2025 – January 6, 2025 (Holiday).

6.3.1.6. The only exceptions to the blackout are:

6.3.1.6.1. Open Tests.

6.4. Application and Reporting Process

6.4.1. An application for each on-Track Test must be submitted to INDYCAR via IRIS for approval.

6.4.2. Applications and notices are due:

6.4.2.1. On-Track Tests: thirty (30) calendar Days before the Test.

6.4.3. INDYCAR may place conditions on its approval of an on-Track Test, including requiring an Official to attend a Test.

6.4.4. Cancellations must be submitted to INDYCAR via IRIS a minimum of seventy-two (72) hours before an on-Track Test. A Member is responsible for all non-refundable INDYCAR expenses.

6.5. Test Participants

6.5.1. Only Members may Test.

6.5.2. Entrants

6.5.2.1. An Entrant must have an Entrant License and membership in INDYCAR for INDY NXT by Firestone.

6.5.3. Drivers

6.5.3.1. A Driver must have a Driver's License and membership in INDYCAR for INDY NXT by Firestone.

6.5.3.2. A Driver may be a Driver other than the Entrant's current Driver(s).

6.5.3.3. Unless otherwise specified, any combination of Drivers may Test.

6.5.4. Manufacturers

6.5.4.1. A Manufacturer must have an Associate's membership in INDYCAR for INDY NXT by Firestone.

6.5.5. All Other Individuals and Entities

6.5.5.1. All other individuals and entities must have memberships in INDYCAR for INDY NXT by Firestone.

6.6. Approved Testing

6.6.1. An Entrant must allow other Entrants to attend a Team Test, up to the maximum number allowed by a venue.

6.6.2. Test Days must be utilized as follows:

6.6.2.1. January 19th and 20th – Sebring International Raceway

6.6.2.2. February 22nd and 23rd – Miami

6.6.2.3. April 14th and 15th – Mid-Ohio

6.6.3. Open Tests

6.6.3.1. The Open Tests are:

- 6.6.3.2. April 2, 2026 – Nashville Superspeedway
- 6.6.3.3. April 22, 2026 – WWTR
- 6.6.3.4. June 23, 2026 – Milwaukee Mile
- 6.6.3.5. TBD – Indianapolis Motor Speedway Chris Griffis Memorial
- 6.6.3.6. Other Entrants may be invited to attend Open Tests subject to INDYCAR approval.

6.6.4. Rookie Driver Tests - Oval

- 6.6.4.1. For purposes of this Rule, Rookie Driver status is determined after the completion of the final Race.
- 6.6.4.2. All Rookie Drivers must complete ROP during the Open Test at Iowa Speedway, Nashville Superspeedway or as otherwise determined by INDYCAR.

6.6.5. Tire Manufacturer Tests

- 6.6.5.1. Tire Manufacturer Tests will be permitted at the sole discretion of INDYCAR.

6.7. Tires

- 6.7.1. Tires from a Testing allotment are subject to availability with Tire Manufacturer and approved by INDYCAR.

6.7.2. Open Tests

- 6.7.2.1. For Open Test Tire allotment, please refer to Tire Allotment chart in [Chapter 15 - Tires](#).

6.8. Locations

- 6.8.1. Tests may occur at the following INDYCAR-approved locations:

- 6.8.1.1. All current INDY NXT by Firestone United States Race Locations, except Street Courses.

6.8.1.2. Road Courses

- 6.8.1.2.1. Circuit of the Americas
- 6.8.1.2.2. Homestead Miami Speedway
- 6.8.1.2.3. NOLA Motorsports Park
- 6.8.1.2.4. Sebring International Raceway
- 6.8.1.2.5. Sonoma Raceway
- 6.8.1.2.6. Watkins Glen International
- 6.8.1.2.7. Autobahn
- 6.8.1.2.8. Buttonwillow Raceway Park (East Course)
- 6.8.1.2.9. New Jersey Motorsports Park
- 6.8.1.2.10. Putnam Park (Media/TV/Photograph Tests only)
- 6.8.1.2.11. Thermal Club

6.8.1.3. Ovals

- 6.8.1.3.1. Homestead Miami Speedway
- 6.8.1.3.2. Kentucky Speedway
- 6.8.1.3.3. Phoenix International Raceway

- 6.8.1.4. Other venues as pre-approved by INDYCAR.

6.9. Additional Testing Limitations

- 6.9.1. Testing for non-Full-Season Entrants shall be at the discretion of INDYCAR.
- 6.9.2. Members agree to provide a minimum of one (1) hour of media availability per on-Track Test Day.
- 6.9.3. Test Days and/or mileage may only be used by the specified Entrant. They must not be sold or assigned.
- 6.9.4. An INDYCAR-approved private Test facilitator(s) must be present at all on-Track Tests, except as otherwise approved by INDYCAR. Each Entrant agrees to cooperate with the directions of the private Test facilitator(s).
- 6.9.5. The following Testing is not permitted:
 - 6.9.5.1. Model wind tunnel
 - 6.9.5.2. Full-size chassis wind tunnel
 - 6.9.5.3. Rig/Dynamometer of any type (excluding Dampers)
 - 6.9.5.4. Straight-line
- 6.9.6. Members must not Test in simultaneous on-Track activity with any non-INDY NXT by Firestone Cars.

6.10. Violations

- 6.10.1. Violations of the Testing Rule will result in a loss of up to fifty (50) Entrant points, fifty (50) Driver points, and/or a fine not to exceed \$500,000.

7. AT TRACK PROCEDURES

7.1. On-Track Conditions

7.1.1. INDYCAR determines the Track Condition. Track Conditions include the following:

7.1.2. Green Condition – The Green Condition signifies racing conditions.

7.1.3. Yellow Condition – The Yellow Condition signifies caution.

7.1.3.1. Oval Events – All Drivers shall reduce speed immediately, proceed with caution, maintain position and yield to safety vehicles and/or personnel.

7.1.3.1.1. Practice/Qualifications – Lap timing ceases at the declaration of a Yellow Condition. Cars are required to return to their respective Pit Boxes.

7.1.3.2. Road/Street Courses (Local) – All Drivers shall demonstrate caution as defined by the criteria set forth in Rule 7.2.2.1. (a) & (b) and be prepared to stop. Overtaking is not permitted between the first Yellow Condition and the subsequent Green Condition. Any Driver passing through a Local Yellow Condition in Practice or Qualifying will have that lap time invalidated.

7.1.3.3. Race

7.1.3.3.1. The Pit Lane will not be closed under Green or Yellow Conditions unless otherwise announced by INDYCAR.

7.1.3.3.2. The Cars' positions are determined by the last timeline crossed on-Track at the moment of the Yellow Condition or Full Course Yellow Condition, except as provided in Rule 7.1.3.3.5.4. INDYCAR shall announce during the Competition Meeting, a lap/time remaining window when Cars' positions will be determined by their actual position on-Track, regardless of last timeline crossed. Should a Race be completed during a Yellow or Full Course Yellow Condition, Cars' positions shall be determined by their actual position on-track at the moment of the Yellow Condition or the Full Course Yellow Condition, regardless of last timeline crossed.

7.1.3.3.3. INDYCAR will dispatch the Pace Car to pick up the Race leader. Cars must form a single file line and pack up behind the Pace Car. INDYCAR may allow one or more Cars to pass any Car not packing up immediately.

7.1.3.3.4. Cars exiting Pit Lane rejoin on the Track according to their Blend Line order.

7.1.3.3.5. A Car may pass another Car, only if:

7.1.3.3.5.1. Both Cars are in Pit Lane boundaries,

7.1.3.3.5.2. The other Car is stopped on the Track,

7.1.3.3.5.3. The Driver of the other Car has waved by all of the passing Cars in an INDYCAR-specified location and approved by INDYCAR, or

7.1.3.3.5.4. The other Car is not maintaining the Pace Car speed only upon direction of INDYCAR.

7.1.3.3.5.5. The other Car is involved in an incident and/or incident in progress. Final determination of ordering of Cars involved in an incident to be made by INDYCAR. INDYCAR's decision is not subject to review and/or appeal.

7.1.3.4. A Car must not use Pit Lane to improve its position relative to the Pace Car or any Car remaining on the Racing Surface, but a Car may improve its position relative to other Cars in Pit Lane.

7.1.3.5. INDYCAR shall determine if the leader or any other Car fails to pace the Race as directed. INDYCAR shall determine the penalty. Such decision is not subject to review and/or appeal.

7.1.3.6. Abandonment of Procedures – INDYCAR may abandon any or all Yellow Condition procedures. Procedures that may be abandoned include, but are not limited to:

7.1.3.6.1. the wave-by (Rule 7.7.1.1) and/or,

7.1.3.6.2. moving cars not on the lead lap to the rear of the restart lineup (Rule 7.7.1.2)

7.1.3.6.3. INDYCAR will announce over the Team Broadcast frequency any changes to the standard Yellow Condition procedures prior to them being abandoned.

7.1.4. Red Condition – The Red Condition signifies suspension of on-Track activities. All Drivers are required to slow to caution speed, maintain position and yield to safety vehicles and personnel. All timing and scoring shall be suspended at the declaration of the Red Condition.

7.1.4.1. Practice/Qualifications – Cars are required to return to their Pit Boxes.

7.1.4.1.1. Practice (Road/Street Courses) – Any Driver involved in an incident that results in the declaration of a Red or Yellow Condition will be subject to the following:

a) A Driver involved in an incident that results in the declaration of Red or Yellow Condition during a practice session will be assessed a penalty of three (3) minutes of Green Condition time during that session.

b) Any Driver requiring the assistance of Track Safety/Officials during the Red or Yellow Condition will may be subject to Rule 7.1.4.1.1a.

7.1.4.2. Parade and Pace Laps / Race – The following procedures will be in effect:

a) Competitors must proceed cautiously to a location designated by Officials.

b) Three (3) crew members are allowed over the wall to attend to the Car and Driver.

- c) Unless otherwise approved by INDYCAR, the work permitted on Cars while in the designated location consists of plugging in a booster battery, applying towels to bodywork, providing the Driver a drink bottle and fan, and placing fans in the radiator boxes and brakes ducts for cooling. Cars must return to their Pit Boxes for any additional work.
 - d) Items which may produce a safety issue must be repaired, replaced and/or removed at the direction of INDYCAR. Cars must return to their Pit Boxes for work.
- 7.1.4.2.1.** INDYCAR approved work performed on a Car while under a Red Condition, including under Rule 7.1.4.2d, will result in the Car being placed at the rear of the Restarting Lineup.
- 7.1.4.2.2.** If a Car is in its Pit Box, behind the pit wall or in the garage when the Red Condition is declared, all work must stop until the Red Condition has been withdrawn.
- 7.1.4.2.3.** If a Car cannot proceed from the Track to Pit Lane, it must return to its Pit Box when able to do so, and no work may be performed until the Red Condition has been withdrawn.
- 7.1.4.2.4.** Unapproved work performed on a Car not related to INDYCAR approved safety issues while under a Red Condition will result in that Car being prohibited from further participation in that Event.
- 7.1.4.3. Red Condition – Tires**
- 7.1.4.3.1.** If track conditions warrant, the Race will be red flagged and Teams must change to “wet” Tires. Upon direction from Race Control, drivers will proceed to their pit boxes and Teams will have five minutes to change tires. Teams may not begin any work until Race Control announces the final car has entered their assigned pit box. Additional changes can be made to accommodate the conditions provided work is completed within the allotted amount of time.
- 7.1.4.3.2.** Once time has expired, Teams must be ready to resume the Race. Teams who do not leave the pit area when requested will restart at the rear of the field.
- 7.1.4.3.3.** Cars will restart in the order they were running before the red flag including all cars who may have changed to “wet” Tires before the red flag was declared. Any Cars in the Pit Lane at the time of the Red Flag will restart at the rear of the field.
- 7.1.4.3.3.1.** Subsequent changes to “Dry” Tires may only occur after taking the green flag on the Race Track.
- 7.1.4.3.4.** Red Condition – intent to restart the race on the same day – Cars may be moved to an impound area
- 7.1.4.3.5.** Only the following work may be performed:
- 7.1.4.3.5.1.** Booster battery connected
 - 7.1.4.3.5.2.** Car radio turned off
 - 7.1.4.3.5.3.** Car cover must be installed
 - 7.1.4.3.5.4.** INDYCAR will set time windows in which Cars may be started to maintain Engine temperatures. INDYCAR will consider ambient temperature for this process. These set windows will be the only approved times Engines may be started.
 - 7.1.4.3.5.5.** Any Car requiring an Engine start outside of set windows may do so only with INDYCAR approval and will be moved to the rear of the Restarting Lineup per Rule 7.7.2.4.
- 7.1.4.4. Red Condition – intent to restart the race on following day(s) – Cars may be moved to an impound area**
- 7.1.4.4.1.** Only the following work may be performed:
- 7.1.4.4.1.1.** Battery disconnected
 - 7.1.4.4.1.2.** Car radio removed
 - 7.1.4.4.1.3.** Car cover must be installed
 - 7.1.4.4.1.4.** Two (2) hours prior to the restart of the race Engine, oil and gearbox heaters may be installed
 - 7.1.4.4.1.5.** All Cars must be started and ready to grid 30 minutes before the restart
- 7.1.4.5.** Red Condition - Cars released to the Teams – no work restrictions.
- 7.1.4.6.** It will be at INDYCAR’s discretion whether a Car being repaired on pit lane or in the garage area when the Red Condition is declared will be eligible to continue in the Event.
- 7.1.5.** The decision as to whether to declare a Green, Yellow, Full Course Yellow Condition, or Red Condition may not be reviewed and/or appealed.
- 7.1.6.** While additional information regarding Track Condition is included in the Flag Code and Track condition lights section for convenience, this information is equally applicable to the other systems of notification (track lights, pit closed lights, team broadcast frequency, track condition radio and instant messaging).
- 7.1.7.** Decisions by INDYCAR are effective immediately, regardless of the time the declaration is received by the Competitors. INDYCAR uses multiple systems to notify Competitors of such decisions and will make a reasonable effort to declare Track Condition changes at the time they are determined. All Competitors shall react to the first notification they receive. The systems include the following:
- 7.1.7.1.** Track Lights – Green, Yellow and/or Red lights positioned around the Track.

7.1.7.2. "Team Broadcast Frequency" – The radio frequency used by INDYCAR to provide direct communication to Entrants during Events. The spotter (if applicable) and a representative of the Entrant in the Entrant's Pit Box must both monitor the Team Broadcast Frequency. Entrants failing to monitor the Team Broadcast Frequency shall be charged with knowledge of communication on such frequency and are subject to penalty. Member radios, with the exception of Officials, must not be capable of transmitting on this frequency. Members failing to follow directions may be penalized.

7.1.7.3. Marshalling System – An in-Car Marshalling system activated by INDYCAR. Modules, harnesses and antennas must be used and specified by INDYCAR, and the antennas must be mounted in the INDYCAR-specified location. The Marshalling System must be operational during all on-Track activity.

7.1.7.3.1. Oval Events –The EM System can signal a Yellow or Red Condition.

7.1.7.3.2. Road/Street Course Events –The EM system can signal a Full Course Yellow Condition during a Race or Red Condition during practice or Qualification sessions. Local flags can be signaled in all sessions.

7.1.7.4. Instant Messaging – A two-way software messaging system used to provide direct text communication between Entrants and INDYCAR during Events. INDYCAR will send messages where applicable to the Entrant(s). This system may be used to communicate Track conditions, send warnings, penalties, or other information to the Entrant. The system may send information to an individual Entrant or to all Entrants. All Entrants must connect to the INDYCAR-supplied instant messaging system prior to Cars going on-track.

7.1.7.4.1. Instant Messaging Protocol – Entrants may send relevant messages to INDYCAR. Use of the instant messaging system for any reason, including, without limitation, irrelevant, abusive, and/or unnecessarily repetitive messages, will result in monetary penalties. Requests for review of any on-track activity should include specific information (location, approximate time or lap number, car numbers, etc.). Reports without specific details will receive lower priority.

7.2. Flag Codes and/or Track Condition Lights (collectively, "Flags")

7.2.1. Green - signifies a Green Condition.

- a) Practice – A practice session has begun.
- b) Qualifications – A Qualifications attempt, or segment has begun.
- c) Race – Unless otherwise instructed, a Race has started or re-started.

7.2.1.1. Road/Street Courses Events Only – Signifies the end of the Yellow Condition at the point where the flag is displayed, or track condition light is illuminated.

7.2.2. Yellow – signifies a Yellow Condition. During Road/Street Course Events:

7.2.2.1. Local – Signifies the start of the Yellow Condition at the point where the flag is displayed, or track condition light is illuminated.

- a) Motionless – A motionless yellow flag means a hazard beside or near the edge of the Track or forewarning of a waved yellow flag ahead. Overtaking is not permitted. Drivers must be prepared to reduce speed substantially, be prepared to take evasive action, and safely interact with other Drivers to the satisfaction of INDYCAR. Failure to demonstrate caution based on any or all the above factors may be subject to penalty.
- b) Waved – A waved yellow flag means a hazard wholly or partially blocking the Track. Overtaking is not permitted. Drivers must reduce speed substantially, be prepared to take evasive action, or stop, yield to safety vehicles and/or personnel, and safely interact with other Drivers to the satisfaction of INDYCAR. Failure to demonstrate caution based on any or all the above factors may be subject to penalty.

7.2.2.2. Full Course – Standing double yellow flags displayed at all marshal's posts, including the starter's stand.

7.2.3. Black – The Driver shall proceed to his/her Pit Box on the next lap and follow the instructions of INDYCAR.

7.2.3.1. INDYCAR may declare a black flag for a Car if it determines that:

- a) Any condition exists which could cause the Driver or the Driver's Car to create a hazard to the Driver or others;
- b) The Driver has violated a Rule; and/or
- c) The Entrant has requested the black flag.

7.2.3.2. When a Driver is ordered to his/ her Pit Box because of a hazardous condition of the Driver's Car, the proper repairs must be made and approved by INDYCAR before the Car will be permitted to continue in the Event.

7.2.3.3. In the event of a violation of the Rules, the black flag may be declared to impose a penalty (a "black flag penalty") requiring a Driver to:

- a) Drive through Pit Lane at Pit Lane speed limits ("drive through");
- b) Stop in his/her Pit Box ("stop and go"); or
- c) Stop in his/her Pit Box for a prescribed period ("stop and hold").

7.2.3.4. INDYCAR shall determine the type of black flag penalty. Service of a black flag penalty for a Rules violation must be initiated under Green Conditions and the penalized Car must cross the Start/Finish line under Green Conditions prior to entering the Pit Lane to serve such penalty except as described elsewhere. The penalized Car shall proceed to the Pit Lane as directed by INDYCAR and may return to competition only upon the declaration of INDYCAR. In the case of a Driver violating the Rules, no work may be performed on a Car during the execution of a black flag penalty. Should any such work occur, the conditions of the penalty are unfulfilled, and the penalty procedure must be executed again in its entirety on a subsequent lap. The penalty may not be reviewed and/or appealed.

7.2.4. Black with White Cross – INDYCAR has ceased scoring the Car indefinitely.

7.2.5. Blue – signifies that an approaching Car is attempting to overtake.

7.2.5.1. At Road/Street Course Events – When displayed from the starter's stand and ordered directly by INDYCAR (command blue), directs a Lapped Car to immediately give way to the overtaking Car. INDYCAR may disable Push to Pass for Lapped Cars (defined as a Car that is at least one lap behind all Cars that are on the Race Leader's Lap)

7.2.5.2. Pit Lane Exit Light – For Road and Street Course Events only, an additional blue light is positioned at the Pit Lane exit and notifies a Driver leaving Pit Lane that a Car on-Track is in close proximity.

7.2.6. White

7.2.6.1. Oval Event Qualifications – The Car has commenced its last lap.

7.2.6.2. Road/Street Course Events – When displayed from a marshal's post, a Car or safety vehicle is not at full speed on the Racing Surface.

a) **Motionless** – means a slow Car at more than 1/3 racing speed is ahead or as a forewarning of a waved white flag ahead.

b) **Waved** – a very slow Car at less than 1/3 racing speed is ahead or a moving safety vehicle is ahead.

7.2.6.3. All Races – When displayed from the starter's stand, the leader has commenced his/her last lap and will continue to be displayed to all successive Cars as they cross the finish line.

7.2.7. White with Red Cross – When displayed from the starter's stand, safety vehicles and/or personnel are on-Track.

7.2.8. Alternating Red and Yellow Stripes – Oil, water or other substance has altered the Racing Surface.

7.2.9. Checkered – The practice session, Qualifications session or Race is completed. All Drivers must enter Pit Lane after receiving the checkered flag.

7.2.9.1. Road/Street Course Events – The checkered flag will be displayed at the marshal's post nearest the alternate start/finish line at the end of practice and Qualifications sessions. All Drivers must immediately enter Pit Lane after receiving the checkered flag at this point.

7.2.9.2. Final Practice Sessions – The checkered flag will be displayed at the start/finish line.

7.2.9.3. Race – The checkered flag will be displayed to the Race leader at the start/finish line upon the completion of the Race Leader's final lap and will continue to be displayed until each Car running has received the checkered flag.

7.2.10. Red – Signifies a Red Condition.

7.2.10.1. As determined by INDYCAR, a Race stopped by the declaration of a Red Condition may be considered complete. If INDYCAR schedules the continuation of the Race on a subsequent date or a later time, the Race will be restarted beginning with the unfinished portion of the Race.

7.2.10.2. Officials will make reasonable efforts to restart a Race stopped by the declaration of a Red Condition if the conditions warrant.

7.2.10.3. INDYCAR's decision to restart or not to restart a Race stopped by the declaration of a Red Condition may not be reviewed and/or appealed.

7.3. Timing and Scoring

7.3.1. General

7.3.1.1. INDYCAR records the physical order in which each Car crosses each timeline, including the Start/Finish Line.

7.3.1.2. The start time, number of laps, and/or amount of time of each Race Event will be specified in a bulletin.

7.3.2. Race Distance and/or Time Limit

7.3.2.1. INDYCAR shall announce the scheduled number of laps and time limit prior to the start of a Race. A Race will be considered complete when either the lap count or time limit is reached, whichever occurs first. INDYCAR may determine that there are time limitations due to weather, curfew, track conditions or otherwise, and INDYCAR may move the start time of a Race, shorten the distance or time of a Race, set a maximum distance or time for a Race, or take such other actions as it deems appropriate.

7.3.3. Systems

7.3.3.1. The electronic system is the primary record.

7.3.3.2. INDYCAR may also consult with other Officials, review camera footage, and consider such other data as necessary or appropriate to decide the order of the Cars.

7.3.4. Start/Finish Line – The scoring of Cars shall begin at the moment when:

7.3.4.1. A single start/finish line will be defined across the Track and extended across the Pit Lane, where appropriate, in the immediate area of the starter's stand.

7.3.4.1.1. Road/Street Course Events – INDYCAR may designate alternate or separate start/finish lines.

7.3.4.2. The scoring of Cars shall begin at the moment when:

7.3.4.2.1. Practice

7.3.4.2.1.1. Oval – the declaration of the Green or Yellow Condition has been given.

7.3.4.2.1.2. Road/Street Course – when the timing transponder of the first car crosses the alternate start/finish line.

7.3.4.2.1.2.1. Should no car cross the alternate start/finish line within a reasonable amount of time after the declaration of the Green Condition, the timing of the Session will begin.

7.3.4.2.1.3. Road/Street Course Final Practice/warmup – the declaration of the Green or Yellow Condition has been given.

7.3.4.3. Qualifications

7.3.4.4. Oval – the declaration of the Green Condition has been given by INDYCAR.

7.3.4.5. Road/Street Course Events – the timing transponder of the first Car crosses the alternate start/finish line.

7.3.4.6. Race – the timing transponder of the lead Car reaches the starting line after the prescribed number of parade and pace laps have been completed.

7.3.4.7.

7.3.5. Lap Credit

7.3.5.1. A Car is credited with a lap when its timing transponder crosses the Start/Finish Line after completing one (1) entire lap of the Track.

7.3.5.2. A Car is the first (1st) Car out of the Race and is awarded the final assign based on the following order:

7.3.5.2.1. The Car is listed in the official Qualifications posting, but it is not in position in the Starting Lineup on the Grid and does not start a Race.

7.3.5.2.2. The Car is in position in the Starting Lineup on the Grid, but it does not start the Race,

7.3.5.2.3. The Car drops out during the parade or pace laps, or

7.3.5.2.4. The Car drops out of a Race before completion of the first (1st) lap.

7.3.5.2.4.1. In the event more than one (1) Car is affected in one (1) or more of the above categories, such Cars will be ranked based on their positions in the original Starting Lineup.

7.3.5.3. If a Car returns to Pit Lane under its own power and retires from the Race, INDYCAR may credit the Car with completion of the lap.

7.3.5.4. On the last lap of a Race, a Car will be officially credited with a lap when any part of the Car under its own power crosses the finish line.

7.3.5.5. At Oval Events, Drivers must not place any of the four wheels of the Car below the solid boundary line at any time.

7.3.5.6. As soon as practical after the completion of an Event, INDYCAR will post the unofficial results.

7.3.5.7. Once the competition review and technical inspection is completed, INDYCAR will post the official results.

7.3.5.8. Final standings will be determined by the sequence in which the Cars completed the scheduled number of laps.

7.3.5.8.1. Except as provided in Rule 7.3.5.4, a Race will be completed by the Race winner at the moment the timing transponder of the Car crosses the start/finish line on the last lap. The Race will be completed by each other Car when the timing transponder of each Car crosses the start/finish line after the Race leader. Scoring will thereafter cease and the Race is completed. INDYCAR's decision may not be reviewed and/or appealed.

7.3.5.8.2. Cars not completing the scheduled number of laps will be ranked in order by total laps completed and sequence of completion, whether the Car is still running or not. INDYCAR shall determine the "reason out" for each Car not listed as running.

7.3.6. Ties

7.3.6.1. In the event INDYCAR is unable to conclusively determine any difference in the physical sequence for two or more Cars at the end of a Race, INDYCAR shall determine the finishing positions based upon the Cars' positions at the start/finish line on the prior lap.

7.3.6.2. In the event two or more Cars post the identical number of laps led in a Race, the Car finishing the Race in the higher/highest position will earn the award for most laps led.

7.3.6.3. INDYCAR's decisions are not subject to review and/or appeal.

7.3.7. Shortcuts – A Car will not be permitted to advance or maintain its position or time relative to other Cars due to an excursion off the Racing Surface.

7.3.7.1. At least two (2) wheels of a Car must remain on the Track at all times, unless otherwise approved by INDYCAR.

7.3.7.2. Practice/Qualifications – Cars shortcutting the course will have the shortcut lap time invalidated.

7.3.7.3. Race – If evasive action results in the advancement of position or time relative to Cars on-Track, INDYCAR may reposition Cars in accordance with Rule 9.2.2.4.

7.4. Communication

7.4.1. In-Car Radio & Radio Location

7.4.1.1. All voice radio transmissions to and from the Car must be in the 450.000-470.000 MHz range. Analog 12.5K narrowband spacing bandwidth channels are the only in-car radio voice transmission and reception permitted. The in-Car radio must not be capable of

transmitting or receiving in a digital format. Radio transmissions must not be encrypted, scrambled or otherwise modified to affect INDYCAR's ability to record, scan and hear at any time during the Event. Channel hopping transmissions to or from the in-Car radio are not permitted.

7.4.1.2. The in-car voice radio must only have their two (2) pre-designated analog frequencies (primary and the backup) programmed into the in-car radio and these two frequencies must be unique from all other in-car transceivers.

7.4.1.3. All in-car voice radio analog frequencies will use a DCS/DPL code that is unique to all other car's DCS/DPL code.

7.4.1.4. Radios may not be located in the cockpit area.

7.4.2. Frequencies – Each Member transmitting or receiving any signal including, without limitation, voice, data and telemetry, but excluding Internet related Wi-Fi (regulated pursuant to Rule 7.4.4.) shall:

7.4.2.1. Provide the specifications (e.g., frequency, manufacturer, make, model and serial number) of the radio to be used in the Car and otherwise, to the INDYCAR-designated representative prior to their first Event;

7.4.2.2. Not password-protect or otherwise affect or limit the INDYCAR-designated representative's ability to scan and hear the radio to be used in the Car at any time;

7.4.2.3. Notify the INDYCAR-designated representative immediately upon changing any of the equipment specifications or frequencies of the radio to be used in the Car and otherwise;

7.4.2.4. Consent and hereby does consent, to the recording, broadcast and/or rebroadcast by INDYCAR or its designee of any such transmissions through any and all media and for any and all purposes; and

7.4.2.5. Comply with all applicable laws regarding such use and indemnify and hold INDYCAR Group harmless with respect to failure to comply with applicable laws, even if the violation involves INDYCAR Group's or its designee's sole or contributory negligence.

7.4.2.6. All non in-car two way radio voice communication must use the "very Narrow" bandwidth 6.25KHz.

7.4.3. Radio Communication

7.4.3.1. During all on-Track Events, radio communication between the Driver and the Entrant's Pit Box is required at all times.

7.4.3.2. Car-to-Car radio communication is not permitted.

7.4.4. Wireless Data Frequency ("Wi-Fi") - Each Member transmitting or receiving any signals for wireless data transmissions shall: (i) coordinate and modify frequencies for use with other wireless data networks as specified by INDYCAR; (ii) limit the use of Wi-Fi to hot spot use only (the use of Wi-Fi backhaul and hi gain antennas is not allowed); (iii) comply with all applicable laws regarding such use; and (iv) indemnify and hold INDYCAR Group harmless with respect to failure to comply with applicable laws, even if the violation involves INDYCAR Group's sole or contributory negligence.

7.5. Pit Boxes

7.5.1. Pit Boxes will be assigned by Team using the below criteria:

7.5.1.1. First Event of Season the pit box order, by team, will be based off team's highest finishing entrant championship points from previous season.

7.5.1.2. All remaining events, Teams will be ordered based on Qualifying results by each Team's highest qualifying Driver from the previous event. All Team Cars will be ordered together based upon the Team's highest qualifying Car.

7.5.1.3. At a Double-Header Race Location, the Pit Boxes will not be moved between Race One and Race Two.

7.6. Race Start

7.6.1. The Pole Position Car will start from the inside of the front row. Each Car must be in position in the Starting Lineup during the parade and pace laps until declaration of the Green Condition.

7.6.1.1. If a Driver is not in the Car and completely ready to compete when the 3 minute to the command to start engines is given by Race Control, the Car will be required to start at the rear of the Starting Lineup, unless otherwise directed by INDYCAR.

7.6.1.2. If a Car is not in position prior to the beginning of the pace lap, the Car must start from the rear of the Starting Lineup.

7.6.1.2.1. If two or more Cars are affected, INDYCAR decides the positions of the Cars at the rear of the Starting Lineup.

7.6.1.3. All other Cars must remain in their positions in the Starting Lineup, unless otherwise directed by INDYCAR.

7.6.2. If a Car is in Pit Lane or the garage area and not in position in the Starting Lineup when the scoring for the Race begins, the Car's first (1st) scored lap will start as the Car leaves the Pit Lane.

7.6.3. If a Car does not leave the Grid after the command by INDYCAR, it must return to its Pit Box or another area as designated by INDYCAR.

7.6.4. A Pace Car will be used to pace the Cars at the start of the Race. The Pace Car will have its flashing lights on during the parade and pace laps. At the appropriate time, the lights will be turned off, indicating the intent to start the Race the next time across the starting line. The Pace Car will pull off into the designated location.

7.6.5. All Drivers must maintain their relative positions until the Green Condition is declared.

7.6.6. Upon INDYCAR's declaration, all Cars must start a Road/Street Course Race on "wet" Tires. Changes may be made to the Cars on the Grid to accommodate the "wet Tires". After such a declaration has been made, a Car must complete one (1) official lap on "wet Tires", which must begin under a Green Condition as is determined by INDYCAR. The lap may be completed in Pit Lane even if the Car's Pit Box is prior to the Start/Finish line.

7.7. Race Restart

7.7.1. After a Yellow Condition

7.7.1.1. Cars between the Pace Car and the Race leader are waved by:

- 7.7.1.1.1. The wave-by will take place as soon as practical,
- 7.7.1.1.2. The Pit Lane may re-close until the waved-by Cars are packed up,
 - 7.7.1.1.2.1. The Pit Lane will re-open after the full pack-up is established, and
- 7.7.1.1.3. The restart may occur as early as the lap after the Pit Lane has re-opened.
- 7.7.1.1.4. Command Blue eligible Cars will restart from the rear of the Restarting Lineup.

7.7.1.2. After the starter gives the “one (1) lap to go” signal and prior to the restart, Cars must line up in single file formation with no gaps or lagging between Cars. In the event of a restart late in the Race, all Cars not on the lead Car lap will be moved to the rear of the Restarting Lineup per the following:

- 7.7.1.2.1. All Events (excluding Road America) – 10 laps or less remaining
- 7.7.1.2.2. Road America – 5 laps or less remaining
- 7.7.1.2.3. In the event of a timed Race, INDYCAR shall announce during the Competition Meeting, the time window at which all Cars not on the lead Car lap will be moved to the rear of the Restarting Lineup.

7.7.2. At the appropriate time, the Pace Car lights will be turned off, indicating the intent to restart the Race. The leader is required to maintain a minimum of the pace lap speed until reaching the restart zone designated by INDYCAR when the leader shall accelerate smoothly back to racing speed and the Green Condition will then be declared. Any manipulation of pace, rapid acceleration, or braking is subject to penalty. Should the leader not accelerate prior to reaching the end of the restart zone, the Green Condition will be declared. The location of both the restart zone and designated restart line (Road/Street Course Events only) shall be announced during the Competition Meeting.

7.7.3. After a Red Condition – All of the standard restart procedures after a Yellow Condition shall apply with the following exceptions:

- 7.7.3.1. The order will be determined by the physical sequence of the Cars at the declaration of the Red Condition.
- 7.7.3.2. If a Car is unable to restart after the command by INDYCAR, it must return to its Pit Box or another area designated by INDYCAR.
- 7.7.3.3. Provided the Car maintains its lap count relative to the leader, a Car may take its position at any time prior to the start of the “one-to-go” lap. After this time, the Car shall be moved to the rear of the Restarting Lineup.
- 7.7.3.4. Notwithstanding Rule 7.7.2.1, the following reasons may be cause for a Car to be placed at the rear of the Restarting Lineup:
 - a) Cars involved in the incident that caused the Red Condition. The decision as to whether a Car has been involved in an incident may not be reviewed or appealed;
 - b) Cars stopped on the Track, including the Pit Lane, during the last officially scored lap; and/or
 - c) Cars which have performed work under Rule 7.1.4.2.1.
- 7.7.3.4.1. The order of Cars placed at the rear of the Restarting Lineup will be in order of total laps completed and sequence of completion.
- 7.7.3.5. Any laps being run under a Yellow Condition will be scored. Any Cars remaining in Pit Lane at the time of a restart may join the Race if approved to compete by INDYCAR.

7.8. Mechanical Conditions

- 7.8.1. INDYCAR shall determine whether a Car involved in a crash or with a hazardous mechanical condition will be permitted to continue in the Event.
- 7.8.2. Parts damaged during the Race may only be replaced by an exact matching part or assembly.
- 7.8.3. INDYCAR shall determine how a disabled Car is removed and where the Car is taken. INDYCAR is not responsible for payment, reimbursement, damage, or loss to any Car as a result of such removal and with respect to the location to which the Car is taken.
- 7.8.4. After any repairs have been completed, the Car is subject to visual or other inspection by INDYCAR prior to being permitted to continue in any further competition.
 - 7.8.4.1. Road/Street Course Races – Cars being repaired will not be permitted to return to a Race during the last 10 laps or 10 minutes of a timed Race or as approved by INDYCAR.
 - 7.8.4.2. Oval Races – Cars being repaired will not be permitted to return to a Race during the last 10 laps or as approved by INDYCAR.
- 7.8.5. A Car may only receive on-Track assistance as directed by INDYCAR. A Competitor may not leave his/her Pit Box to assist a Car unless approved by INDYCAR.
- 7.8.6. Officials may approve technical or structural changes during technical inspection due to contact, material, or parts failure.
- 7.8.7. These decisions of INDYCAR are final and may not be reviewed and/or appealed.

7.9. Performance Standards

7.9.1. INDYCAR may establish a performance standard which all Entries entered in an Event must achieve in order to participate in the Event. In general, Entries must perform within 105% of the Car posting the best time and demonstrate Car consistency, control/placement and interaction with other Cars on-Track to the satisfaction of INDYCAR. In general, the performance standard will be announced to all Competitors prior to the start of the first practice session. However, INDYCAR may delay announcement of the standard until a later time based on the physical condition of the Track, safety and other considerations.

7.10. Pit Procedures

- 7.10.1.** Cars will not be permitted to enter or exit Pit Lane from the Garage area under their own power.
- 7.10.2.** The Race Director may declare Race conditions for any on-Track activity.
- 7.10.3.** All Cars must be centered in their assigned pits. The Car must be parallel to the pit wall.
- 7.10.4.** Equipment and tires on the Trackside of pit wall must be attended by a crew member at all times.
- 7.10.5.** An Entrant is not permitted to utilize a signboard without an Official's approval.
- 7.10.6.** Except as otherwise provided by the Rules, all personnel and equipment must remain within the assigned pit.
- 7.10.7.** A speed limit not exceeding 35 mph shall be enforced within the Pit Lane. While INDYCAR publishes Pit Lane speed limits in mph, INDYCAR shall calculate a Car's Pit Lane speed by dividing a Car's distance traveled by time. All distances and times shall be measured by INDYCAR. No other method of speed measurement shall be utilized or considered.
- 7.10.8.** No refueling or removal of fuel is permitted during any session, the race, or at any time prior to the completion of post-qualifying or post-race technical inspection. Fueling is permitted in the paddock/garage or fuel service area. Fuel may not be stored in an Entrants garage.
- 7.10.9.** A maximum of three (3) crew members are allowed over the wall when changing tires (wet to dry / dry to wet) This applies at all times during the Race and Qualifications. The "wall" is defined as an imaginary line drawn between the team's pit equipment and the race car. Wheels must be torqued at or above the Dallara recommendation. The penalty for this violation is a drive-through penalty. Additional penalties may apply.

7.11. Pit Safety Violations

- 7.11.1.** Any of the following matters and any others which may be determined by the Series may be cause for a Car to be penalized:
 - 7.11.1.1.** Failing to follow designated procedures entering or exiting the pit area, including the proper use of the fast lane, transition lanes, and pit exit commit lanes.
 - 7.11.1.2.** Car that makes contact with its own pit equipment while entering or exiting its Pit Box causing a safety issue and/or causing the pit equipment to leave its assigned Pit Box and/or impeding the progress of any other Car.
 - 7.11.1.3.** Car that makes contact with another Car's pit equipment, causing a safety issue and/or impacting that Car's pit stop and/or impeding the progress of any Car.
 - 7.11.1.4.** Contact with another Car.
 - 7.11.1.5.** Contact with personnel or hitting equipment and causing it to contact personnel.
 - 7.11.1.6.** Car entering a Pit Box other than the Car's assigned Pit Box.
 - 7.11.1.7.** Unsafe release of a Car from its Pit Box.

8. QUALIFICATIONS

8.1. General

- 8.1.1. Meeting** – INDYCAR may hold a specific meeting prior to the start of any Qualifications. INDYCAR may designate the meetings as mandatory for some Members.
- 8.1.2. Starting Time** – INDYCAR shall determine the starting time for the Qualifications period.
- 8.1.3. Delays** – INDYCAR may penalize any Member attempting to delay or delaying Qualifications.
- 8.1.4. Interruption** – Qualifications may be interrupted by the commencement of a Yellow or Red Condition. Qualifications is suspended at the moment that the decision to interrupt is made. The decision to interrupt a Qualifications attempt or Qualifications (and reasons therefore) may not be reviewed and/or appealed.
- 8.1.5. Once Qualifications has begun and throughout the remainder of the Event, the aerodynamic configuration of the Car can only be changed by the addition and/or removal of approved individual parts and not by the changing of assemblies.**
- 8.1.5.1. Parts damaged** may only be replaced by exact matching parts or assemblies.
- 8.1.6.** Each entrant is only permitted one set of tires for use during qualifications.
- 8.1.7. Technical Inspection**
- 8.1.7.1. Data Download** – Unless approved by INDYCAR, Entrants may not download data during the following time periods until released from technical inspection:
- 8.1.7.1.1.** after the checkered flag has been displayed for any Qualifications session; or
- 8.1.7.2. Impound Area** – Officials shall direct selected Qualified Cars to a designated “impound area” to check for compliance. A maximum of two crew members per Car will be permitted in the impound area.
- 8.1.7.3. Cars** – INDYCAR reserves the right to seal any component.
- 8.1.7.4. Fuel** – A fuel sample may be taken from all Cars prior to and after the Qualifications attempt.
- 8.1.8. Backup Cars** – The same Car must be used in Qualifications and the Race at a Race Location unless approved by INDYCAR.
- 8.1.8.1.** If a Qualified Car is involved in an incident, INDYCAR allows a Backup Car to replace the Qualified Car. The Backup Car will start the Race in the same position in the Starting Lineup as the Qualified Car.
- 8.1.8.2.** If a Qualified Car is unable to start a Race for any reason other than an incident, INDYCAR decides if a Backup Car may replace the Qualified Car. If INDYCAR allows the Backup Car to replace the Qualified Car, the Backup Car will start the Race from a revised position at the rear of the Starting Lineup.
- 8.1.9. Starting Lineup**
- 8.1.9.1.** INDYCAR shall determine the size and configuration of the Starting Lineup for each Race. The configuration of the Starting Lineup may include Qualified and non-Qualified Cars. The performance standard shall apply to all Cars at all times during an Event.
- 8.1.9.2.** Except as otherwise provided by these Rules, the Starting Lineup shall be determined by best time rankings, from fastest to slowest, with the fastest Qualified Car occupying the Pole Position, followed by the second fastest Qualified Car, third fastest, and down through the slowest Qualified Car that has not been bumped from the Race.
- 8.1.9.3.** In the event two or more Cars post identical official Qualifications times, the Cars shall be ranked in the order in which the completed Qualifications attempts occurred.
- 8.1.9.4.** A Driver who has qualified a Car may not make an attempt to qualify a second Car unless the first Car has been withdrawn from the Event with permission of Officials or the first Car has been eliminated from the Starting Lineup.
- 8.1.9.5.** Starting positions shall include penalties issued during Qualifications and post-Qualifications technical inspection.
- 8.1.9.6.** If after the Starting Lineup has been determined, a Car has had its Qualifications time and/or original Starting Lineup position changed or disallowed, INDYCAR shall assign the Car a revised Starting Lineup position at the rear based on the following order:
- a) Cars without a Rules violation, and
 - b) Cars with approved driver substitution; and
 - c) Cars with a Rules violation.
 - d) If more than one Car is affected in any of these categories:
 - At the first Race of the Racing Season, the Cars shall be ranked using the prior year’s end of season Entrant point standings. INDYCAR shall determine an Entrant’s eligibility.
 - At all other Races during the Racing Season, the Cars shall be ranked using the current year’s Entrant point standings entering the Race.
 - Any Car without Entrant points entering the Race will be ranked based on the Qualifications order behind all Cars with points.
- 8.1.10. Provisional Starting Cars**
- 8.1.10.1.** INDYCAR may offer Provisional Starting Cars at any Event if the total number of Entries for the Event exceeds the available pit space. If Provisional Starting Cars are offered, INDYCAR shall issue a bulletin detailing the Qualifications procedures and Starting Lineup prior to the first practice session.

8.1.11. Starting Lineup Determination – Qualifications Not Completed

8.1.11.1. All Events:

- a) At the first Race of the Racing Season, the Cars shall be ranked using the prior year's end of season Entrant point standings. INDYCAR shall determine an Entrant's eligibility.
- b) At all other Races during the Racing Season, the Cars shall be ranked using the current year's Entrant point standings entering the Race.
- c) Any Car without Entrant points entering the Race will be ranked based on the Qualifications order behind all Cars with points.

8.2. Oval Events

8.2.1. Qualifications Order – INDYCAR shall determine the Qualifications order by Entrant points. Qualifications order will be set in reverse order of Entrant points, with the highest in points qualifying last. Entrants without points will be placed at the front of the line in an order determined by a blind draw at the first Competition meeting for that Event.

8.2.1.1. If no Entrants have Entrant points, Qualifications order will be set in the reverse order of Entrant points based on the prior year's end of season Entrant point standings. Entrants without points during the prior year will be placed at the front of the line in an order determined by a blind draw.

8.2.2. Qualifications Line

8.2.2.1. Cars must be in the technical inspection line thirty (30) minutes before the beginning of Qualifications.

8.2.2.2. A Car reserves its position in the Qualifications line as long as it remains in the designated position and proceeds with the Qualifications attempt when signaled. INDYCAR's decision is not subject to review and/or appeal.

8.2.2.3. While the Car is in the Qualifications line, an Entrant's representatives may make front/ rear wing angle, and Tire pressure adjustments only. The Car must be moved as the Qualifications line progresses. A Car must not leave the Qualifications line without the approval of INDYCAR.

8.2.3. Technical Inspection

8.2.3.1. If a Car does not present itself for the technical inspection line at the designated start time as determined by INDYCAR, the Car shall forfeit its "Guaranteed Attempt" and may be listed at the rear of the Starting Lineup pursuant to [Rule 8.1.8.6](#). Cars experiencing an on-track Engine failure or crash may be granted a delayed entry time into the technical inspection line provided INDYCAR has granted prior approval. Car must be presented into its original spot in the Qualifications line prior to its departure time.

8.2.3.2. When a Car is presented for technical inspection:

- a) Fuel buckeye openings may be fitted with blanking covers; and
- b) Bodywork seams may be taped provided the tape does not change the intended shape of the part. Covering of fasteners is also permitted.

8.2.3.3. Once a Car has reached the entry to the technical inspection area, no external device may be connected to the Car unless approved by INDYCAR.

8.2.3.4. Once the Car is four (4) Cars from its Qualifications attempt, Entrant may plug in a computer and/or booster battery.

8.2.3.5. Prior to Engine start, all computers or any other external devices must be disconnected. Cars experiencing Engine start difficulties must have approval from INDYCAR prior to connecting any device.

8.2.3.6. The Car must remain as presented to the pre-Qualifications technical inspection line throughout the entire Qualifications attempt unless otherwise approved by INDYCAR.

8.2.3.7. Retracting the brake pistons into the caliper by any method is prohibited.

8.2.3.8. Only after a Car's Qualifications attempt or post-Qualifications technical inspection is completed, whichever occurs later, may any of the approved aerodynamic options, approved Homologated options, or approved mechanical options be changed.

8.2.4. Declaration of Intent

8.2.4.1. A Car must be presented at the entrance of the "staging pit" when signaled to do so ("declaration of intent"). INDYCAR shall signal a Driver when it is time for the Car to depart from the Qualifications line to begin a Qualifications attempt. Unless otherwise provided by INDYCAR, each Car must depart the Qualifications line within sixty (60) seconds of receiving the signal.

8.2.4.2. In order to make an official Qualifications attempt, a Car must have been given the signal to depart from the Qualifications line and have moved away under its own power prior to the end of the Qualifications period. Notwithstanding the end of the Qualifications session, a Car may begin its Qualifications attempt, provided it has received the signal and is moving with its Engine running. The Car is not required to have completed its Qualifications attempt prior the end of the Qualifications session.

8.2.4.3. A Car may not be pushed to start its Engine at the start of a Qualifications attempt.

8.2.4.4. A Car shall be given two (2) warm-up laps. INDYCAR may add additional warm up laps, as it deems appropriate.

8.2.5. Qualifications Attempt

8.2.5.1. Qualifications will be based on one (1) individually timed attempt per Car.

8.2.5.1.1. At single-race Events, a Qualifications attempt is the total of the two (2) consecutively timed laps.

8.2.5.1.2. At double-header Events, a Qualifications attempt consists of two (2) consecutively timed laps:

8.2.5.1.2.1. The first timed lap shall be the Qualifications time for Race 1; and,

8.2.5.1.2.2. The second timed lap shall be the Qualifications time for Race 2.

8.2.5.2. Each Car will be permitted only one (1) departure from the Qualifications line to commence its Qualifications attempt. A Qualifications attempt may only be started and completed under the Green Condition.

8.2.5.3. All Cars in the Qualifications order shall be given one "Guaranteed Attempt" to qualify. Notwithstanding the foregoing, the following matters and any others as determined by INDYCAR are cause for a Car to forfeit its Guaranteed Attempt and to be listed at the rear of the Starting Lineup in accordance with Rule 8.1.8.6.

- a) A Car is not presented in the proper order to the technical inspection line at the designated time, notwithstanding Rule 8.2.4.1.;
- b) A Car does not successfully complete technical inspection;
- c) A Car is not presented in the proper order at the staging pit;
- d) A Car fails to leave the staging pit within the designated time;
- e) A Car leaves the staging pit but fails to receive the green flag; or
- f) A Car fails to receive the checkered flag.

8.2.5.3.1. If more than one Car is so affected, the Cars shall be ranked according to Rule 8.1.9.6.

8.2.5.4. If the Qualifications period concludes before each Car has been given its "Guaranteed Attempt", then Qualifications shall resume at a time designated by INDYCAR, if practicable. If INDYCAR is unable to resume Qualifications and allow each Car its Guaranteed Attempt, the entire Starting Lineup shall be determined in accordance with Rule 8.1.8.10.

8.2.5.5. INDYCAR interrupts Qualifications attempt:

8.2.5.5.1. If the interruption is caused by a Car's Entrant or Driver and occurs during a Car's Guaranteed Attempt, such Car shall forfeit its Qualifications attempt and may be listed at the rear of the Starting Lineup in accordance with Rule 8.1.8.6.

8.2.5.5.2. If the interruption is not caused by a Car's Entrant or Driver, such Car shall not be charged with a Qualifications attempt and the Car may be permitted to return to its position at the front of the existing Qualifications line and proceed with its Qualifications attempt when Qualifications resumes. The only changes that may be made to the Car are Tires may be changed, radiator shutters' opening size may be increased, and fuel added. If INDYCAR cannot resume Qualifications, INDYCAR shall preserve the Qualifications line already established. If INDYCAR releases a Car during a suspension, the Entrant is not required to keep its Car at the designated location during the suspension. Officials shall announce prior to resuming Qualifications that all Cars are to be returned to the designated location. Any Entrant not returning an Entrant's Car to the designated location by the designated time shall forfeit the Entrant's Guaranteed Attempt and may be listed at the rear of the Starting Lineup in accordance with Rule 8.1.8.6.

8.3. Road/Street Courses

8.3.1. Race Qualification Groups

8.3.1.1. Cars are divided into one (1) of two (2) groups.

8.3.1.2. Groups are decided by the lap times in the practice session immediately preceding Race Qualifications.

8.3.1.3. The Car with the best lap time in the practice session immediately preceding the Qualifying session, decides groups for Race Qualifications. The entrant must choose the group upon the completion of the practice session immediately preceding Race Qualifications.

8.3.1.3.1. If the Car with the best lap time chooses Group one (1):

8.3.1.3.2. Group One (1): Cars in the odd numbered positions, and

8.3.1.3.3. Group Two (2): Cars in the even numbered positions.

8.3.1.3.4. If the Car with the best lap time chooses Group Two (2):

8.3.1.3.5. Group One (1): Cars in the even numbered positions, and

8.3.1.3.6. Group Two (2): Cars in the odd numbered positions.

8.3.1.4. Qualifying Session

8.3.1.4.1. Each group has ten (10) minutes of Track time, including the opportunity for one timed lap.

8.3.1.4.2. At the Road America and Arlington Events two (2) minutes of time shall be added to each group.

8.3.1.4.3. The Car with the best overall lap time earns the Pole Position.

8.3.1.4.4. The remaining Cars in the Pole Position Car's group will be ranked by best lap time in Qualifications in the odd numbered positions, starting with position three (3). Cars in the other group will be ranked by best lap time in Qualifications in the even numbered positions, starting with position two (2).

8.3.1.4.5. The fastest in each Group will receive one (1) Championship point.

8.3.1.4.6. Double race events will use the Car's second-best lap time from each Group for Race Two (2) starting positions.

8.3.1.4.7. The first and second starting position for Race 2 will receive one (1) Championship point.

8.3.1.5. Timing of the session will begin when the transponder of the first Car crosses the alternate start / finish line.

8.3.1.5.1. Should no car cross the alternate start/finish line within a reasonable amount of time after the declaration of the Green Condition, the timing of the Session will begin

8.3.1.6. Attempt Not Completed

8.3.1.6.1. If one or more cars does not post a time within its respective group, such Cars will be ranked at the rear of its respective group based upon Qualifications order.

8.3.1.7. Race One (1) and Race Two (2) Alternate Procedures – Session Not Completed

8.3.1.7.1. All Cars will be ranked by Entrant point standings entering each Race.

8.3.1.7.2. Any Cars without Entrant points entering the Race will be ranked based on the Qualifications order behind all Cars with points.

8.3.1.7.3. Points are not earned.

8.3.2. Qualifications attempt

8.3.2.1. If a Car causes a Red Condition in any segment, the Car's best two (2) timed laps of the segment shall be disallowed, the Car may not continue in the segment, and the Car shall not advance to the next segment.

8.3.2.2. If a Car interferes with the Qualifications attempt of another Car other than through a Red Condition, the Car's two (2) best-timed laps shall be disallowed.

8.3.2.3. During Group One (1) and Group Two (2), timing of the session will stop at the declaration of the first Red Condition of each Group. Timing will resume immediately at the declaration of a Green Condition. Timing will not stop for subsequent Red Conditions.

8.3.3. If a Car causes a Yellow Condition that requires another Car to comply with Rule 7.1.3.2, the Car's best-timed lap to that point during that Qualifications segment shall be disallowed, regardless of whether the other Car complied with Rule 7.1.3.2. If the Car does not have a timed lap recorded when causing the Yellow Condition, a Black Flag drive-through penalty will be assessed once the lap on which the Yellow Condition occurred has been completed.

8.3.4. Segment Extension

8.3.4.1. If a green condition occurs prior to the completion of any segment, INDYCAR may delay the display of the checkered flag to allow each car leaving pit lane enough time for one (1) timed lap. Each car must leave its pit box within thirty (30) seconds of the green condition.

8.3.5. Attempt Not Completed

8.3.5.1. If one or more Cars does not post a time, such Cars will be ranked at the rear of the Starting Lineup based upon:

- c) Entrant Points
- d) Random draw

8.3.5.2. A Car receiving a penalty will be ranked in the rear of the Starting Lineup subject to the order presented in Rule 8.1.8.6.

8.4. Qualifications Impound – At select Events, INDYCAR may impose mandatory Qualifications Impound procedures per the following.

8.4.1. Qualifications Impound – All Events

8.4.1.1. During impound, INDYCAR will set time windows in which Cars may be started to maintain Engine temperatures. INDYCAR will consider ambient temperature for this process. These set windows will be the only approved times Engines may be started.

8.4.1.1.1. Any Car requiring an Engine start outside of set windows may do so only with INDYCAR approval and will be moved to the rear of the Starting Lineup per Rule 8.1.9.6.

8.4.1.2. Prior to Cars being gridded, INDYCAR will announce times and procedures for adding teams' desired amount of race-starting fuel.

8.4.1.3. Penalties for Car aerodynamic and mechanical configuration changes during impound are as follows:

8.4.1.3.1. Changes with prior INDYCAR approval may result in the penalized Car being moved to the rear of the Starting Lineup per Rule 8.1.9.6.

8.4.1.3.2. Changes without prior INDYCAR approval will result in the penalized Car being moved to the rear of the Starting Lineup per Rule 8.1.9.6 and a minimum of a drive through penalty.

8.4.2. Qualifications Impound – Oval Events

8.4.2.1. All Events

8.4.2.1.1. Once a Car is in line for Qualifications technical inspection, the Car will be impounded. Approved changes as listed in Rule 8.2 may be performed.

8.4.2.1.2. Each Entrant is required to start the Race on the same set of tires as used during Qualifications, unless waived by INDYCAR in the Drivers meeting.

8.4.2.1.3. Penalties for tire changes between Qualifications and the Race are as follows:

8.4.2.1.3.1. Tire changes with prior INDYCAR approval may result in the penalized Car being moved to the rear of the Starting Lineup per Rule 8.1.8.6.

8.4.2.1.3.2. Tire changes without prior INDYCAR approval will result in the penalized Car being moved to the rear of the Starting Lineup per Rule 8.1.8.6. and a minimum of a drive through penalty.

8.4.2.2. Oval Impound No Work Window

8.4.2.2.1. INDYCAR will record the aerodynamic configuration of the Car and require the Car to be in the same configuration for the Race start, excluding adjusting front wing flap angles.

8.4.2.3. Oval Impound with Work Window

8.4.2.3.1. At the conclusion of each Car's Qualifications attempt, the Car will remain impounded in a designated location. During this impound, INDYCAR will indicate a time during which a maximum of three (3) crew members will be allowed access to the Car to conduct any of the following permitted work.

- Adjust front wing flap angles
- Adjust tire pressures
- Apply cooling towels
- Place driver cooling fans
- Install race radio
- Change car battery
- Plug into download port
- Inlet Shutters
- Left side front face radiator Shutter(s)
- Change AiM Camera SD card
- Remove and/or add helicopter tape to bodywork seams
- Program spare steering wheel
- Place electronics cooling fans

8.4.2.3.2. Car Configuration - For the Race, Cars must be in the aerodynamic and mechanical configuration in which they were presented to pre-qualifications technical inspection, excluding approved changes as noted in Rule 8.4.2.3.

9. PENALTIES

9.1. General

9.1.1. INDYCAR may penalize any Member for any violation of the Rules. If an Official observes or is made aware of an act or omission by a Member that constitutes a violation of the Rules, the Official shall promptly report the violation to INDYCAR. INDYCAR shall consider the report and shall conduct whatever additional inquiry it deems appropriate under the circumstances. After concluding the inquiry, INDYCAR shall determine whether disciplinary action is appropriate and if so, what disciplinary action should be taken. The Member shall be informed of the determination and if disciplinary action is imposed, INDYCAR shall issue a penalty notice to the Member specifying the violation, a brief statement of the circumstances of the violation and the penalty imposed. If the act or omission of a Member is determined by INDYCAR to constitute a threat to the integrity or safety of INDYCAR, INDY NXT by Firestone or to the orderly conduct of an Event or to constitute a violation during an Event, INDYCAR may take immediate action against the Member.

9.1.2. The Race Steward(s) and/or Race Director shall monitor violations of the Sporting Regulations of the Rules during Qualifications and/or Races. The Race Steward(s) and/or the Race Director may request a Review at any time. Each official votes for or against the issuance of a penalty, a majority vote determines if a penalty is issued, and the individual votes are not released or made public. Once this determination is made, the Race Steward(s) and/or Race Director shall determine the severity of the penalty from the Penalty Guidelines developed by INDYCAR based on majority vote. An Official will notify the Race Director who shall advise the Competitors and broadcast/media of the determination and/or penalty either: (i) "Car # ___ was under Review and no further action is required" or (ii) "Quoting Rule # ___ and Car # ___, the penalty is issued."

9.2. Scope of Penalties

9.2.1. Penalties for violations of the Rules are divided into two categories: Race Procedure penalties and non-Race Procedure penalties. Penalties are determined by the gravity of the violation and its impact on the fairness of competition, the orderly conduct of the Event and the interests and integrity of automobile racing, INDYCAR and INDY NXT by Firestone. INDYCAR shall have the authority to impose any or all or any combination of the following penalties against any Member for any violations of the Rules at any time.

9.2.2. Race Procedure Penalties – Violation of Race Procedures generally result in penalties imposed during on-Track activity. If circumstances do not permit a penalty to be served during on-Track activity, INDYCAR shall declare the results provisional and subject to examination which shall take no longer than one (1) hour after the displaying of the checkered flag. This examination is independent of the Competitor's requirement to pass post-Race technical inspection. If the imposition of a penalty is near or at the end of the on-Track activity and the Driver/Car does not fulfill it, INDYCAR may reposition the Driver/Car in the posting of results. Additional penalties may be applied to subsequent on-Track activities to reflect the fulfillment of the penalty. Except as provided in Rule 10.2.1, the penalty, including without limitation any repositioning in a posting, is non-reviewable and/or appealable.

9.2.2.1. Black Flag – INDYCAR may impose black flag penalties.

9.2.2.2. Laps – INDYCAR may impose lap penalties. Lap penalties shall be imposed in complete laps only. The imposition of a lap penalty shall result in the removal of official credit for the specified number of penalty laps from the total laps credited to the Competitor and the scoring records and all points and awards shall reflect the removal of penalty laps.

9.2.2.2.1. If the lap penalty is imposed during the on-Track activity, the removal of official credit shall begin with the Competitor's lap in which the violation occurred and shall include subsequent consecutive laps, as determined by INDYCAR.

9.2.2.2.2. If the lap penalty is imposed after the on-Track activity is completed, INDYCAR shall determine, based on the severity of the violation, whether the removal of official credit shall begin with the Competitor's last lap and include previous consecutive laps as required, or begin with the Competitor's lap in which the violation occurred.

9.2.2.2.3. INDYCAR shall make a reasonable effort to notify the penalized Competitor of a lap penalty at the time it is determined. However, failure to notify the Competitor during the on-Track activity will in no way mitigate or change the penalty.

9.2.2.3. Time – INDYCAR may impose time penalties as described below. The imposition of a time penalty may result in the removal or addition of the specified amount of time to the Competitor and the timing and scoring records and awards shall reflect the removal or addition of time.

9.2.2.3.1. If the time penalty is imposed during a subsequent on-Track activity, the time shall be removed from the Entrant's Open Test or Team Test, practice session and/or Qualifications period. The time penalty must be fulfilled when directed by INDYCAR. The time penalty begins when the Member, the Member's Car and Entrant personnel are in Pit Lane.

9.2.2.3.2. If the time penalty is imposed during the current on-Track activity, time shall be removed or added to the Entrant's overall time on the official posting.

9.2.2.4. On-Track Repositioning – INDYCAR may impose a repositioning penalty during on-Track activities. The repositioning penalty will result in an order change of the Car's on-Track position. The recipient of the repositioning penalty may not pit until a Green Condition occurs, unless approved by INDYCAR.

9.2.2.5. Starting Lineup Repositioning – INDYCAR may impose a Starting Lineup penalty. A Starting Lineup penalty is repositioning of an Entrant in the Starting Lineup. If a Starting Lineup repositioning penalty is announced, the recipient of the repositioning penalty may not pit until a Green Condition occurs, unless approved by INDYCAR.

9.2.2.6. Disqualification – INDYCAR may disqualify the Member. Disqualification shall entail the loss of any right to compete in the remainder of the current Event from the time at which the disqualifying condition first occurred. It may entail the forfeiture of Entry fees paid or payable and INDYCAR shall determine, based on the severity of the violation, whether or not the disqualification includes the forfeiture of points and awards earned up to the moment at which time the infraction for the disqualification first occurs.

9.2.3. Non-Race Procedure Penalties – Violations of non-Race Procedures generally result in penalties imposed during off-Track activity. Penalties are reviewable and/or appealable except as provided in Rule 10.2.2.

9.2.3.1. Additional Appearances and/or Meetings – INDYCAR may require a Member to attend and actively participate in appearances and/or meetings in addition to those required of the Member, other Members, pursuant to the Rules and any other agreements.

INDYCAR may specify the due date for completion. Failure to attend and/or participate by the due date may result in reinstatement of the monetary fine if a monetary fine was imposed, or additional penalties as determined by INDYCAR.

9.2.3.2. Monetary Fines – INDYCAR may issue monetary fines and specify the due date for payment. Unpaid fines may be deducted from any awards payable by INDYCAR to the Entrant or Manufacturer associated with such Member. INDYCAR may suspend or refuse to approve the renewal of the License and/or membership of any Member failing to timely pay any fine during the period the fine remains unpaid.

9.2.3.3. Probation – INDYCAR may place a Member on probation. Probation is a state of limitation upon a Member's privileges. During probation, a Member is under heightened scrutiny and the Member can be required to abide by specified standards of conduct that are more stringent than those which are otherwise applicable to Members under the Rules. If a Member violates probation, the Member is subject to a more severe penalty as determined by INDYCAR. INDYCAR shall determine the duration and conditions of probation, which may include any combination of penalties set forth in [Rule 9.2](#).

9.2.3.4. Suspension – INDYCAR may suspend a Member. A suspension may be total suspension from INDYCAR, or it may be limited to a suspension of membership or License privileges at a Race Location facility or facilities, or for a particular Event or Events, or for a specified or indefinite period of time. Unless expressly limited, a suspension shall entail the loss of any right to take part in any capacity whatsoever in any Event or Events included in the suspension. Unless otherwise stated, individuals under suspension will not be issued credentials of any kind for an Event and the privileges and uses of the Track, pit area, garage area and other restricted areas will be denied. Every suspended individual shall return all credentials and/or Licenses to INDYCAR who will not return them until the term of the suspension has expired. Any delay in surrendering the credentials and/or Licenses may be added to the term of the suspension. If the suspended individual does not return the credentials and/or Licenses, the credentials and/or Licenses shall be inoperative and invalid until the lifting of the suspension and the Member may be subject to additional penalty for failure to return the credentials and/or Licenses. Suspension may also render void any previous Entry made for any Event occurring during the term of such suspension and may entail the forfeiture of any applicable Entry fees paid or payable for any such Entries. INDYCAR shall have the right to reduce, increase, or otherwise modify the unexpired term of a suspension issued under the Rules.

9.2.3.5. Loss of Points and/or Awards – INDYCAR may rule that a Member who violates the Rules will forfeit all or a portion of the points and/or awards earned in that year, including points and awards earned in the Event in which the violation occurred.

9.3. Additional Provisions and Guidelines

9.3.1. Improper Conduct – Any Member attempting to or engaging in unsportsmanlike conduct, unsafe conduct, or conduct detrimental to racing; INDYCAR; and/or to the INDY NXT by Firestone series whether during an Event or on/off the Track, may be subject to any or all penalties. Improper conduct shall include, without limitation:

9.3.1.1. Engaging in reckless, careless, unsafe, and/or overly aggressive actions, or unsportsmanlike behavior;

9.3.1.2. Impeding the conduct of an Event, including Car control, placement and inconsistent driving pattern;

9.3.1.3. Causing an avoidable Yellow or Red Condition;

9.3.1.4. Endangering the safety of Members, or others;

9.3.1.5. Failing to participate at competitive speed;

9.3.1.6. Failing to interact with other Cars on-Track to the satisfaction of INDYCAR;

9.3.1.7. Failing to follow the direction of INDYCAR; and/or

9.3.1.8. Using improper, profane, or disparaging language or gestures in reference to any Official, Members or anyone else or improper, profane or disparaging language or gestures in reference to, concerning or connected in any way with INDYCAR, the INDY NXT by Firestone, NTT INDYCAR SERIES, or any Event and could result in additional penalties as determined by INDYCAR.

9.3.2. Blocking – Any Driver who moves in reaction, altering their line based on the actions of pursuing Competitors, may be penalized.

9.3.3. Avoidable Contact – The primary responsibility for avoiding contact with a Competitor resides with the overtaking Competitor and the secondary responsibility resides with the Competitor(s) being overtaken. A Competitor who fails to demonstrate their responsibility and initiates a maneuver that results in contact with another Competitor may be penalized.

9.3.3.1. Driver Involved in Multiple Contact – Any Driver determined to be in violation of [Rule 9.3.3](#). (avoidable contact) two (2) times during any three (3) consecutive Race Events shall be placed on probation for a period of the Drivers next five (5) Race Events and subject to the conditions set forth in [Rule 9.2.3.3](#).

9.3.4. Team Tactics and/or Team Orders – Team tactics and/or Team orders are actions or omissions by one or more Members to artificially influence, affect, alter, and/or otherwise interfere with the normal course of an on-Track Event. Team tactics and/or Team orders are not permitted. If INDYCAR determines one or more Members attempted to or engaged in Team tactics and/or Team orders, INDYCAR may issue a penalty to any or all of the Members, including without limitation any or all of a Team's Car/Driver combinations.

9.3.5. Assault or Battery – If any Member shall attempt to or commit an assault or battery, such Member may be disqualified and/or suspended by INDYCAR and may be subject to additional penalties.

9.3.6. Gambling Policy – Members have a duty to act with integrity and to protect the integrity of INDYCAR. Gambling involving INDYCAR creates risk to this integrity. Even the perception that INDYCAR competition is manipulated would damage INDYCAR and its Members and other participants. Accordingly, this Rule is adopted to protect the integrity of INDYCAR. Members shall not direct, cause, facilitate, assist or enable others to engage in activities prohibited by this Rule and shall not participate in prohibited activities through an agent or other intermediary. A Member shall cause all individuals who are in the Member Group to adhere to the requirements of this Rule to the same extent as a Member, and a Member shall be responsible for violation of this Rule by Member Group. The Rule shall apply at all times, regardless of whether a Member is participating in an Event.

9.3.6.1. Gambling on INDYCAR Activities - Members shall not directly or indirectly engage, nor attempt to engage, in any gambling activity (as defined below) (i) relating to INDYCAR or any of its sanctioned series, any Event, or any portion of an Event, or (ii) that in the judgment of INDYCAR could represent or represents the potential for a conflict of interest, unsportsmanlike conduct or conduct detrimental to racing and/or INDYCAR Group. For purposes of this Rule only, “Event” includes all activities included within the definition of “Event” (in Rule 19) except that for purposes of this Rule it *includes* all of the following series: INDYCAR SERIES, INDY NXT, Indy Pro 2000 Championship, and USF2000 National Championship. Without limitation, this Rule applies to:

- all gambling activities including without limitation, those available in any gaming facility, casino, lottery gaming facility, racetrack gaming facility, or on the internet or electronically, or in all other establishments and locations;
- all legal and illegal gambling activities; and
- non-Event gambling activities related to INDYCAR including without limitation, which Driver an Entrant will hire, employment matters, penalties or outcomes of appeals.

Gambling activity, for purposes of this Rule, is defined as placing anything of value at risk, whether monetary or otherwise, in connection with a bet, wager, or game of chance.

9.3.6.2. Permitted Gambling – A Member may participate in legal gambling activities that are not prohibited by this Rule. If a Member wishes to participate in any gambling activity that is not prohibited by this Rule in their capacity as an INDYCAR participant (for example, a celebrity blackjack tournament), they may do so only if they have received the prior written authorization of INDYCAR. Such authorization, if granted, will be limited to the extent authorized by INDYCAR. Members shall always conduct themselves with honesty and integrity when participating in any gambling activities that are not prohibited by this Rule.

9.3.6.3. Fantasy Games – Fantasy games (as defined below) are not considered a prohibited gambling activity under this Rule if:

- A Member does not accept prizes with value of more than \$250 in any game;
- The fantasy game does not create an actual or perceived conflict of interest; and
- A Member does not use or attempt to use the fantasy game as a device for tipping (as prohibited in [Rule 9.3.6.5](#)) or other activities prohibited by the Rules or by law.

If INDYCAR determines that a fantasy game is not permitted under this Rule 9.3.6.3, it shall be considered a prohibited gambling activity.

Fantasy games, for purposes of this Rule, are defined as contests in which participants assemble fictional teams of actual participants, with the winners determined by the performance of those participants in Events. Fantasy games includes all games regardless of duration (including season-long games and daily games).

9.3.6.4. Fixing – Members shall not directly or indirectly influence or manipulate or fix any Event to cause or create any occurrence other than that which is the result of honest performance. Members shall not directly or indirectly attempt to so influence or manipulate or fix any Event and shall be subject to penalty even if the attempt was not successful. All actions intended to inappropriately or artificially influence or manipulate or fix any Event, including without limitation the outcome, statistics, conduct or any other occurrence in any Event, are prohibited. Prohibited actions include, but are not limited to, offering, giving, accepting or receiving bribes, gifts, rewards or any other consideration of any kind (whether financial or otherwise) which is or gives the appearance of being related in any way to influencing, manipulating or fixing any aspect of an Event. Members must give their honest, best efforts when competing in Events.

9.3.6.5. Tipping – Members shall not directly or indirectly disclose or attempt to disclose confidential information (as defined below) to any person for the purpose of directing, causing, facilitating, assisting or enabling gambling activity related to INDYCAR and/or the Events. Without limiting the foregoing, Members shall not disclose or attempt to disclose confidential information under circumstances where the Member knows or should reasonably understand that the information will be used to place bets related to INDYCAR or an Event.

Confidential information, for purposes of this Rule, means non-public, proprietary or otherwise sensitive information that could be used in connection with gambling related to INDYCAR or an Event.

9.3.6.6. Reporting Obligation – Members shall immediately report the following to the President and/or the INDYCAR Chief of Staff:

- Any activity known, suspected or anticipated to be non-compliant with this Rule; and
- Any request from any person that the Member engage in any conduct that would violate this Rule.

A Member's duty to report arises when a Member becomes aware or should reasonably have become aware of an activity. Members shall not retaliate against any Member that in good faith makes a report under this Rule.

9.3.6.7. Penalties – Except in the case of complicity (as defined in [Rule 9.3.6.8](#)), a Member violating this Rule will have their membership terminated for a minimum of one year and will be subject to additional penalty as set forth in Rule 9.2.3. Such termination will entail the loss of any right to take part in any capacity whatsoever in any Events. A terminated Member is no longer in good standing with INDYCAR and will not be issued credentials of any kind for any Event, and the privileges and uses of the Track, pit area, garage area and other restricted areas will be denied. A terminated Member shall return all credentials and/or Licenses to INDYCAR who will not return them unless membership is reinstated. If the terminated Member does not return the credentials and/or Licenses, the credentials and/or Licenses shall be inoperative and invalid, and the failure to return such credentials and/or Licenses may be considered by INDYCAR in its determination of whether to reinstate the Member at any time. A Member terminated under this Rule may not apply for reinstatement of membership until expiration of the period of termination as specified in the penalty. Any application

for membership after such time will be evaluated by INDYCAR in its discretion and, if reinstatement is granted, membership may be conditioned upon an agreement to terms and conditions of reinstatement as determined by INDYCAR.

9.3.6.8. A Member shall be subject to penalty as set forth in Rule 9.2.3 for violation of this Rule by an individual who is part of the Member Group.

9.3.6.9. Complicity – Members who do not violate the other requirements of this Rule may nonetheless be determined by INDYCAR to be complicit in its violation. Complicity, for purposes of this Rule, means enabling or assisting others who may have violated this Rule avoid penalty. Complicity may include, without limitation, refusal to cooperate with INDYCAR in investigation of an alleged violation. Members who are complicit in violation of this Rule are subject to penalty as set forth in Rule 9.2.3.

9.3.7. Social Media – Competitors and Officials must comply with provisions of the INDYCAR Social Media Policy at all times.

9.3.8. Detrimental Member Conduct – The favorable reputation of INDYCAR, and its Members, is a valuable asset and creates tangible benefits to all involved. Accordingly, it is an obligation of all Members to refrain from engaging in conduct which is detrimental to INDYCAR and its Members. Such conduct shall include, but not be limited to comments to the news media that unreasonably attack or disparage Members or INDYCAR. Responsible expressions of legitimate disagreement with INDYCAR are not prohibited. However, public comments a Member knows, or should reasonably know, will harm the reputation or financial best interests of a Member or INDYCAR are expressly covered by this Rule.

10. REVIEW

10.1. Introduction

10.1.1. Except as expressly provided in these Rules, the exercise of judgment by Officials during an Event issuing a penalty or otherwise shall not be reviewed and the decision of Officials is final and binding. By submitting a membership application and in consideration of receiving the numerous benefits available, each Member agrees that the final and binding decisions of Officials are non-litigable. No court action of any kind may be taken by any Member. Further, there is no right of review or appeal of any INDYCAR decision or penalty to FIA and/or ACCUS-FIA and/or any other third party including the FIA International Court of Appeals and ACCUS-FIA National Court of Appeals, even if an Event is listed by ACCUS-FIA and/or another ASN on the FIA international calendar. By reason of membership in INDYCAR and/or participation in an Event, any Member waives any rights such Member may otherwise have to be a party or to take any action in court seeking legal or equitable relief against any decision or action of any kind by INDYCAR, the Officials, anyone acting on behalf of INDYCAR, the review facilitator and/or the appeal panel. Each Member acknowledges that participation in an Event by other Members is in part in reliance on this waiver. If a Member initiates or participates in litigation in violation of these Rules, all membership privileges may thereupon be suspended, and Member is subject to the provisions of Rule 1.4 of these Rules.

10.2. When is a Review Permitted

10.2.1. Race Procedure penalties are not subject to review and appeal, except for (i) disqualification, (ii) suspension, (iii) probation, (iv) a monetary fine in excess of Ten Thousand and 00/100 Dollars (\$10,000.00), (v) an award fine, and/or (vi) a point fine.

10.2.2. Non-Race Procedure penalties are subject to review and appeal, provided a review is permitted by the Rules and the request for review is in accordance with these Rules.

10.2.3. An applicant or Member may not request review of the existence or wording of a Rule and/or the non-imposition of a penalty.

10.3. Who May Request a Review

10.3.1. Only the Entrant submitting an Entry may request a review of the rejection of the Entry. Any Competitor who competes in any Event that is not in accordance with the published Entry form conditions waives the right to challenge the non-enforcement of such conditions.

10.3.2. Only the individual or entity submitting a license or membership application may request a review of a decision related to such application.

10.3.3. Only the Member receiving a penalty may request a review of the penalty of the Member.

10.3.4. If more than one Member is involved in the same violation of these Rules, each Member must submit a request for review.

10.4. Process to Request a Review

10.4.1. A request for review shall be in writing and include the following:

- e) Clearly state the errors claimed;
- f) Each claimed error must be stated in specific terms and must be accompanied by a written statement of the facts and grounds upon which it is based.
- g) Designate a single point of contact for the party requesting the review and contain the name, address, e-mail and telephone number for this person who will be the only point of contact concerning the review with respect to such party.

10.4.2. The request for review must be delivered to and received by INDYCAR within two (2) Business Days of issuance of the penalty or decision (not including the day the penalty or decision is issued) and sent via email to:

Rules@indycar.com

10.4.3. A request for review shall be considered received only upon INDYCAR's actual receipt of the request and INDYCAR's email response to the sender confirming INDYCAR's receipt. INDYCAR is not responsible for errors in electronic transmission and/or receipt of the request.

10.4.4. If INDYCAR decides a request for review does not adhere to these Rules, it may be dismissed and treated as if it were not submitted. If the two (2) Business Days have passed, a new request for review may not be submitted. If the two (2) Business Days have not passed, a new request for review may be submitted.

10.4.5. If INDYCAR decides a request for review adheres to these Rules, INDYCAR specifies an individual to serve as review administrator to assist the review party, INDYCAR and the review facilitator with any and all administrative aspects of the review. The review administrator is not involved in any substantive manner in the review. During the review process, the review administrator is the only point of contact for the review party, INDYCAR, and the review facilitator regarding the administrative aspects of the review process.

10.5. Review Process

10.5.1. The review will be conducted by one (1) review facilitator. Prior to the start of each season, INDYCAR will distribute a list of possible review facilitators.

10.5.1.1. Upon receipt of a request for review, the review administrator will notify each individual in the pool of the receipt of a request for review to confirm availability and identify any potential or actual conflicts of interest. The notice may include the general timing for a review, the names of the affected applicants or Member(s), and a brief description of the penalty or decision.

10.5.1.2. Within three (3) Business Days of INDYCAR's receipt of a request for review, INDYCAR shall provide in writing to the party requesting the review the names of three (3) review facilitators from the above list. INDYCAR shall determine the three (3) review facilitators based upon the type of penalty (e.g., technical regulation, sporting regulation); the particular specialization or expertise, availability and conflicts of interest of the review facilitators; and such other factors as may indicate the overall ability of the review facilitator to assist in the review.

- 10.5.1.3.** Within one (1) Business Day of the party's receipt of the three (3) review facilitators from INDYCAR, the party requesting the review shall provide the name of one (1) review facilitator via email to the review administrator. In the event there are multiple parties submitting a review for the same violation of these Rules, the party submitting the first request for review actually received by INDYCAR shall select the review facilitator for and on behalf of such party and all other parties requesting a review.
- 10.5.1.4.** Within one (1) Business Day of INDYCAR's receipt of the one (1) review facilitator from the party requesting the review, INDYCAR shall provide in writing to the party requesting the review confirmation of the status of the review facilitator.
- 10.5.1.4.1.** If INDYCAR confirms the review facilitator is available, INDYCAR shall decide upon an acceptable date for the review meeting.
- 10.5.1.4.2.** If INDYCAR confirms it was unable to contact the review facilitator or INDYCAR contacted the review facilitator, but the review facilitator was unavailable or had a conflict of interest, the party requesting the review shall provide in writing to INDYCAR the name of an alternate one (1) review facilitator from the same list of three (3) facilitators initially provided within one (1) Business Day of receipt of INDYCAR's confirmation. If each of the three (3) individuals could not be contacted, were unavailable and/or had conflicts of interest, the review administrator will notify the party submitting the review in writing of INDYCAR's three (3) alternate individuals in the pool. This process shall continue until such time as a review facilitator has been selected.
- 10.5.2.** Once the review facilitator has been selected, the review administrator provides the review facilitator with the Rules and all applicable bulletins to date. Once the review facilitator has entered into the confidentiality agreement, the review administrator provides the review facilitator with non-public information and documents concerning the review.
- 10.5.3.** The review facilitator must decide if the request for review adhered to the Rules.
- 10.5.4.** If the review facilitator decides the request for review did not adhere to the Rules, the request for review may be dismissed, disregarded as having never been submitted, and the review facilitator may disallow any new submission of the same issue for review.
- 10.5.5.** If the review facilitator decides the request for review adhered to these Rules, the review meeting will be conducted within ten (10) Business Days of the issuance of the penalty with the review meeting date during the time period to be determined by INDYCAR.
- 10.5.6.** The review meeting will be conducted by a review facilitator at the INDYCAR offices located in Indianapolis, Indiana. If the parties and the review facilitator mutually agree, they may decide upon a location other than the INDYCAR offices in Indianapolis, Indiana and/or another location than Indianapolis, Indiana.
- 10.5.7.** The review will take place in the form of a meeting conducted by the review facilitator. The review meeting will be either an in-person meeting or via telephone or video conference. In the event the parties and review facilitator cannot agree on whether the meeting will be in-person, via telephone or via video conference, the review shall be an in-person meeting. The review meeting will not proceed for more than a single day and will not be more than four (4) hours during this day, unless agreed to by the review facilitator and all parties.
- 10.5.8.** The review meeting is not open to the public and admittance is limited to INDYCAR, the party/parties requesting the review and its/their representative(s), and the review facilitator. INDYCAR and the party/parties requesting the review may not appear at the review meeting through or accompanied by legal counsel. Within two (2) Business Days prior to the review meeting, INDYCAR and each party seeking a review shall provide the review facilitator with: i) the names, titles and contact information of all attendees to the review meeting and the purpose for which each will be present at the review meeting, and ii) a summary of its position not to exceed five (5) double spaced pages in length, not including supporting documentation. The total number of attendees at the review meeting is limited to three (3) per party. INDYCAR and each party requesting the review shall have at least one (1) attendee with full authority to reach a resolution of the penalty at the review meeting. The review facilitator does not exchange position summaries with the other parties and/or INDYCAR unless the parties and INDYCAR mutually agree.
- 10.5.9.** The review meeting is limited to the issues raised in the written request(s) for review.
- 10.5.10.** Except as otherwise provided in [Rule 1.1.2.4.](#), [Rule 1.1.3.3.](#), or otherwise in the Rules, the review and all discussions, information and documents concerning the review and at the review meeting are confidential. The party/parties requesting the review and all present at the review meeting or in possession or control of such documents and information shall enter into a confidentiality agreement supplied by INDYCAR prior to the commencement of the review meeting. The review facilitator shall enter into the confidentiality agreement prior to receiving any information and documents concerning the review. Any party that does not timely enter into the confidentiality agreement provided by INDYCAR will not be permitted to participate in the review meeting and such party will no longer have a right to have the penalty reviewed and appealed.
- 10.5.11.** Consistent with the informal and collaborative nature of the review meeting, there shall be no transcript or recording of the meeting and the review facilitator will determine the format. The review facilitator shall decide the number of sessions, whether they are joint or separate, and who will participate in each session, consistent with an opportunity for each participant to present their position and facilitate the resolution of the issue(s) presented.
- 10.5.12.** At the conclusion of the review meeting:
- The review facilitator shall provide her/his thoughts concerning the penalty and whether the penalty should be upheld, overturned or modified and, if modified, provide a recommended modification. Any decision or recommendation by the review facilitator as part of the review process is not binding upon INDYCAR or the party/parties requesting the review and is confidential and subject to the confidentiality agreement set forth in this [Rule 10](#).
- The review facilitator shall allocate the reasonable costs and expenses of the review facilitator amongst INDYCAR and each party submitting a review of the penalty. INDYCAR and each party submitting a review shall bear their own fees, costs and expenses.
- 10.5.13.** During the review meeting and through the conclusion of the appeal process, if applicable, the review facilitator shall not be employed by or on behalf of or otherwise affiliated in any other capacity with INDYCAR and/or any of the parties to the review and/or appeal; however, the review facilitator may continue to serve in his/her capacity as a review facilitator and/or appeal panel member for other requests for review and/or appeal.
- 10.5.14.** During the review process, the review facilitator must strive to uphold the integrity of INDYCAR, the NTT INDYCAR SERIES, and the Events. At all times, the review facilitator must be professional, courteous, and independent.
- 10.5.14.1.** The review facilitator has a duty to disclose any potential or actual conflicts of interest that may exist or arise with regards to any of the review participants.

10.5.14.2. Any appearance of impropriety will not be allowed and may result in removal of a review facilitator from a review and/or from the list of possible review facilitators in these Rules.

10.5.14.3. The review facilitator should refer any media inquiries to the review administrator.

10.5.14.4. The review facilitator must thoroughly review the submissions and familiarize himself/herself with the issues during the review; however, the review facilitator must not perform any independent review or research and/or communicate in any manner about the subject matter of the review by or amount any of the review participants outside of the review process. The review facilitator is expected to vigorously apply the Rules to the facts in order to reach a thorough, thoughtful, and fair decision.

10.5.15. After the conclusion of the review meeting, the review facilitator shall destroy any and all notes, records and/or other electronic and hard copy documents received regarding the review.

10.5.16. Within two (2) Business Days of the review meeting, INDYCAR and each party submitting review shall pay the review facilitator their respective share of the review facilitator costs and expenses.

10.6. Compliance with Procedures

10.6.1. Any request for review that fails to comply with any of the foregoing requirements will be dismissed with prejudice and disregarded as having never been submitted. Any error not specifically raised in the request for review is waived.

11. APPEALS

11.1. Introduction

Except as expressly provided in these Rules, the exercise of judgment by Officials during an Event issuing a penalty or otherwise shall not be appealed and the decision of Officials is final and binding. By submitting a membership application and in consideration of receiving the numerous benefits available, each Member agrees that the final and binding decisions of Officials are non-litigable. Each Member agrees to abide by the decision of the appeal panel. No court action of any kind may be taken by any Member. Further, there is no right of review or appeal of any INDYCAR decision or penalty to FIA and/or ACCUS-FIA and/or any other third party including the FIA International Court of Appeals and ACCUS-FIA National Court of Appeals, even if an Event is listed by ACCUS-FIA and/or another ASN on the FIA international calendar. By reason of membership in INDYCAR and/or participation in an Event, any Member waives any rights such Member may otherwise have to be a party or to take any action in court seeking legal or equitable relief against any decision or action of any kind by INDYCAR, the Officials, anyone acting on behalf of INDYCAR, the review facilitator and/or the appeal panel. Each Member acknowledges that participation in an Event by other Members is in part in reliance on this waiver. If a Member initiates or participates in litigation in violation of these Rules, all membership privileges may thereupon be suspended and is subject to the provisions of [Rule 1.4](#) of these Rules.

11.2. When is an Appeal Allowed

Only penalties satisfying the following requirements may be appealed: penalties subject to review under [Rule 10](#) of these Rules, penalties that have completed the review process under [Rule 10](#) of these Rules, and penalties that are the subject of a request for appeal in compliance with this [Rule 11](#). An applicant or Member may not request appeal of the existence or wording of a Rule and/or the non-imposition of a penalty.

11.3. Who May Request an Appeal

Only the party/parties satisfying the following requirements may appeal a penalty: party/parties that originally submitted the penalty for review under [Rule 10](#) of these Rules, and parties that have participated in the review process under [Rule 10](#) of these Rules, including entering into the confidentiality agreement.

11.4. Submission of Appeals

11.4.1. If an appeal is permitted under these Rules, an appeal shall be in writing and include the following:

- a) Clearly state the errors claimed.
- b) Each claimed error must be stated in specific rather than general terms and must be accompanied by a written statement of the facts and grounds upon which it is based.
- c) Designate a single point of contact for the party submitting the appeal and contain the name, address, e-mail and telephone number for this person who will be the only point of contact concerning the appeal with respect to such party.

11.4.2. The request for appeal must be delivered to and received by INDYCAR within three (3) Business Days after the conclusion of the review meeting set forth in [Rule 10](#) of these Rules (not including the day of the review meeting) and sent via email to:

Rules@indycar.com

11.4.3. A request for appeal shall be considered received only upon INDYCAR's actual receipt of the request and INDYCAR's email response to the sender confirming INDYCAR's receipt. INDYCAR is not responsible for errors in electronic transmission and/or receipt of the request.

11.4.4. If INDYCAR decides a request for appeal does not adhere to these Rules, it may be dismissed and treated as if it were not submitted. If the three (3) Business Days have passed, a new request for appeal may not be submitted. If the three (3) Business Days have not passed, a new request for appeal may be submitted.

11.4.5. If INDYCAR decides a request for appeal adheres to these Rules, INDYCAR specifies an individual to serve as appeal administrator to assist the appeal party, INDYCAR and the appeal panel chair with any and all administrative aspects of the review. The appeal administrator is not involved in any substantive manner in the appeal. During the appeal process, the appeal administrator is the only point of contact for the appeal party, INDYCAR, and the appeal panel chair regarding the administrative aspects of the appeal process.

11.5. Appeal Process and Hearing

11.5.1. An appeal is intended to be formal, as compared to the informal review process.

11.5.2. Except as otherwise provided in [Rule 1.1.2.4.](#), [Rule 1.1.3.3.](#), or otherwise in the Rules, the appeal and all discussions, information and documents concerning the appeal and at the appeal hearing are confidential. The party/parties submitting the appeal and all present at the appeal hearing or in possession or control of such documents and information shall enter into a confidentiality agreement supplied by INDYCAR prior to the commencement of the appeal hearing. Each member of the appeal panel shall enter into the confidentiality agreement prior to receiving any information and documents concerning the appeal. Any party that does not timely enter into the confidentiality agreement provided by INDYCAR will not be permitted to participate in the appeal and such party will no longer have a right to an appeal of the penalty.

11.5.3. There shall be no transcript or recording of the appeal hearing.

11.5.4. The appeal must contain reference to the specific action by Officials from which an appeal is taken, the date of the occurrence, the reasons for the appeal, and the relief requested. The appeal must be accompanied by copies of all written documents pertaining to the appeal, such as the written review request submitted under [Rule 10](#) of these Rules, responses, rulings and declarations. The appeal must clearly and explicitly state the basis of the appeal.

- 11.5.5.** The appeal will be conducted by an appeal panel. To participate in a particular appeal, the panel member must be available and without potential or actual conflicts of interest. The appeal will be heard by an appeal panel comprised of three (3) panel members from a list of possible members provided by INDYCAR prior to the start of each season. In the event there are multiple parties submitting an appeal for the same penalty, the party submitting the first appeal actually received by INDYCAR shall choose the appeal panel for and on behalf of such party and all other parties requesting an appeal.
- 11.5.6.** Upon receipt of a request for appeal, the appeal administrator will notify each individual in the pool of the receipt of a request for appeal to confirm availability and identify any potential or actual conflicts of interest.
- 11.5.7.** Within three (3) Business Days after receiving a written appeal, the appeal administrator shall conduct a conference call with INDYCAR and the person designated as the only point of contact for the party filing an appeal, to choose the three (3) members of the appeal panel. During this conference call, INDYCAR and appeal party shall be ready and have full authority to choose the three (3) member appeal panel. The appeal administrator shall inform INDYCAR and the appeal party of any individuals in the pool with confirmed unavailability and/or with potential or actual conflicts of interest, and those individuals may not be selected for the appeal panel. The appeal party shall choose the first appeal panel member. Next, INDYCAR shall choose an appeal panel member. The third member of the appeal panel will be chosen by agreement of INDYCAR and the appeal party. If INDYCAR and the appeal party cannot agree on the third appeal panel member, three (3) potential appeal panel members will be randomly chosen by INDYCAR from the remaining potential appeal panel members in [Rule 11.5.5](#) above. The appeal party shall strike one potential appeal panel member from this list, then INDYCAR shall strike one potential appeal panel member from this list, and the individual remaining is the third member of the appeal panel and the chair of the appeal panel. The chair of the appeal panel is responsible for coordinating with the other appeal panel members and being the only contact among the appeal panel and INDYCAR and the appeal party/parties regarding all aspects of the appeal and appeal hearing.
- 11.5.8.** Once the three (3) member appeal panel is chosen, the appeal panel shall govern the appeal process and conduct an appeal in-person hearing. Any direction, decision, determination or act by the appeal panel shall be made by a majority vote of the three (3) members of the appeal panel.
- 11.5.9.** During and through the conclusion of the appeal process, the appeal panel members shall not be employed by or on behalf of or otherwise affiliated in any other capacity with any of the parties to the review and/or appeal; however, the appeal panel members may serve in his/her capacity as a review facilitator and/or appeal panel member for other requests for review and/or appeal.
- 11.5.10.** During the appeal process, the appeal panel must strive to uphold the integrity of INDYCAR, the NTT INDYCAR SERIES, and the Events. At all times, the appeal panel must be professional, courteous, and independent.
- 11.5.10.1.** The appeal panel has a duty to disclose any potential or actual conflicts of interest that may exist or arise with regards to any of the appeal participants.
- 11.5.10.2.** Any appearance of impropriety will not be allowed and may result in removal of an appeal panel member from an appeal and/or from the list of possible appeal panel members in these Rules.
- 11.5.10.3.** The appeal panel members should refer any media inquiries to the appeal administrator.
- 11.5.10.4.** Each member of the appeal panel must thoroughly review the submissions and familiarize himself/herself with the issues during the appeal; however, the appeal panel must not perform any independent review or research and/or communicate in any manner about the subject matter of the appeal by or amount any of the appeal participants outside of the formal appeal structure. The appeal panel members are expected to vigorously apply the Rules to the facts in order to reach a thorough, thoughtful, and fair decision.
- 11.5.11.** Once the appeal panel has been selected, the appeal administrator provides the appeal panel chair with the Rules and all applicable bulletins to date. Once each appeal panel member has entered into the confidentiality agreement, the appeal administrator provides the appeal panel chair with non-public information and documents concerning the appeal.
- 11.5.12.** The appeal panel must decide if the request for appeal adheres to these Rules.
- 11.5.13.** If the appeal panel decides the request for appeal did not adhere to these Rules, the request for appeal may be dismissed, disregarded as having never been submitted, and the appeal panel may disallow any new submission of the same issue. The appeal panel must still issue a confidential written decision to the appeal party and INDYCAR.
- 11.5.14.** If the appeal panel decides the request for appeal adhered to these Rules, the appeal hearing shall be concluded within seven (7) Business Days of the submission of the appeal. If the parties and the appeal panel are unable to decide upon an acceptable date during the seven (7) Business Day period, the appeal panel shall decide upon a date within three (3) Business Days after such seven (7) Business Day period (e.g. appeal panel could choose the 8th – 10th Business Day) and such decision is final and binding on the parties.
- 11.5.15.** The appeal panel shall establish the timing and process for each party to submit a written statement concerning the appeal and any supporting documentation; the exact time of the appeal hearing; the duration of the appeal hearing; and who may attend the appeal hearing. INDYCAR and the party/parties requesting the appeal shall be permitted to appear at the appeal hearing through or accompanied by legal counsel. Notwithstanding the foregoing, the timing and process shall include the following components at a minimum:
- 11.5.15.1.** Within two (2) Business Days prior to the appeal hearing, INDYCAR and each party seeking an appeal shall provide the appeal panel with:
- 11.5.15.2.** The names, titles and contact information of all attendees to attend the appeal hearing and the purpose for which each present at will be the appeal hearing, and
- 11.5.15.3.** a summary of its position not to exceed ten (10), double spaced pages in length, not including supporting documentation.
- 11.5.15.4.** The appeal panel does not exchange position summaries with the other parties and/or INDYCAR unless the parties and INDYCAR mutually agree.
- 11.5.15.5.** The appeal panel shall conduct the hearing in the following manner. Prior to opening statements or the submission of proof by the party requesting the appeal, the appeal panel may request that INDYCAR submit an explanation of the basis of its decision.

11.5.15.5.1. Opening Statements – The parties to the proceedings will be permitted to make opening statements, with the party requesting the appeal making the first opening statement. Each party shall state the issue(s) before the appeal panel and a brief summary of the position of the party with respect to such issue(s).

11.5.15.5.2. Order of Proof – The evidence shall be received by the appeal panel in the following order:

11.5.15.5.2.1. The party requesting the appeal shall first submit and present evidence in support of the appeal. Upon the completion of direct examination, each witness shall be subject to cross-examination by the other parties and by the appeal panel.

11.5.15.5.2.2. INDYCAR and the other parties shall then be permitted to present evidence, and any witnesses presented shall be subject to cross-examination by the party requesting the appeal, by other parties, and by the appeal panel.

11.5.15.5.2.3. Closing Arguments – Upon completion of the evidentiary portion of the hearing, all parties, beginning with the party requesting the appeal, may make closing arguments.

11.5.16. The appeal hearing will be conducted at the INDYCAR offices located in Indianapolis, Indiana. If the parties and the appeal panel mutually agree, they may decide upon a location other than the INDYCAR offices in Indianapolis, Indiana and/or another location than Indianapolis, Indiana.

11.5.17. The appeal hearing is not open to the public and admittance to the hearing is by invitation of the appeal panel and can be revoked. The appeal panel shall identify the parties and other necessary participants in the proceedings. Each party is permitted a maximum of three (3) attendees at the appeal hearing, including legal counsel, but not including any Members or other witnesses appearing at the request of the appeal panel. INDYCAR and each party requesting the appeal shall have at least one (1) attendee with full authority at the appeal hearing. The appeal panel may summon any Member to testify at the hearing. If a Member is called as a witness and fails to appear, INDYCAR may revoke the Member's License and/or membership and/or otherwise penalize the Member.

11.5.18. The hearing shall be confined to the errors claimed in the appeal and evidence relevant to those errors.

11.5.19. The appeal panel shall not be limited to the technical common law rules of evidence required in judicial proceedings but shall be satisfied the evidence submitted is of a type on which the appeal panel can rely. The appeal panel may exclude irrelevant, immaterial, or unduly repetitious evidence.

11.5.20. All parties to the proceedings shall be permitted to present and cross-examine witnesses and to submit evidence, both oral and documentary. The burden of proof shall remain at all times on the party/parties submitting the appeal.

11.5.21. The decision of the appeal panel is final and binding on INDYCAR and each party submitting an appeal. An appeal panel decision may not include the re-drafting of a Rule and/or a Penalty Guideline. The appeal panel shall issue a confidential written determination of the appeal within three (3) Business Days of the conclusion of the appeal hearing and this written determination is subject to the confidentiality agreement set forth in this Rule 11. After the conclusion of the appeal hearing, the appeal panel shall destroy any and all notes, records, and/or other electronic and hard copy documents received regarding the appeal.

11.5.22. The appeal panel shall allocate the reasonable costs and expenses of the appeal panel amongst INDYCAR and each party submitting an appeal of the penalty. INDYCAR and each party submitting an appeal shall bear their own attorneys' fees, costs and expenses. Within ten (10) Business Days from the appeal panel's decision, INDYCAR and each party submitting an appeal shall pay the appeal panel their respective share of the remaining appeal panel costs and expenses.

11.6. Compliance with Procedures

11.6.1. Any appeal that fails to comply with any of the foregoing requirements will be dismissed with prejudice and disregarded as having never been submitted. Any error not specifically raised in the appeal shall be deemed to have been waived.

12. CHAMPIONSHIP AND POINTS

12.1. Championships and Point Standings

12.1.1. INDYCAR recognizes several different types of championships, including, without limitation, Entrant and Driver. To facilitate competition for these championships, INDYCAR calculates and publicizes complete rankings of all participating, Entrants and Drivers following the completion of each Race. Unless otherwise announced by INDYCAR, all scheduled Qualifications and Races shall offer championship points.

12.1.2. At the end of the Racing Season, Entrant and Driver with the highest number of ranking points respectively shall be declared the Champion.

12.2. Significance of the Car Number

12.2.1. Points and awards are credited only to the Entrant entered in the Event and to the Driver participating in that Car except as otherwise permitted by INDYCAR. The Car number is listed on the Entry and signifies the Car to be credited. The points and awards accumulate on behalf of the entered Car number, separately from any other Entrant's License that Team may hold.

12.3. Crediting of Points

12.3.1. INDYCAR has established the following system under which eligible, Entrants and Drivers may accumulate points.

12.3.2. Entrant points will be credited only to an Entrant holding a valid Entrant's License at the time of the Event, competing with a properly entered Car and displaying the assigned Car number throughout any Event.

12.3.3. Driver points will be credited only to Drivers holding a valid Driver License at the time of the Event.

12.3.4. INDYCAR will not credit the point(s) usually earned by the Entrant and Driver starting a Race in the Pole Position if the Starting Lineup is determined in accordance with Rule 8.1.8.10.

12.3.5. If a Car participates in practice and/or Qualifications, but is unable to start a Race, the Driver and/or the Entrant shall receive half of the points the Car would have received for the Race had the Car started the Race ("non-starting Cars"). INDYCAR shall determine whether a Car is deemed to have participated for purposes of this Rule.

12.3.6. Unless otherwise provided by INDYCAR, all Entries shall be eligible for Entrant and Driver points associated with participation in an Event.

12.4. Ties

12.4.1. In any instance of a tie, INDYCAR will determine the ranking based on the following criteria:

- a) The most first place finishes,
- b) The most second place finishes through last place finishes,
- c) The best finishing position in the previous Event, or
- d) Random draw.

12.5. End of Season Awards

12.5.1. INDYCAR reserves the right to establish end of season awards based upon points.

12.6. Points

12.6.1. Points may be earned by Entrants and Drivers based upon participation in Races and Qualifications.

12.6.2. Entrant/Driver Race Points – INDYCAR will award points pursuant to finishing position as follows:

	Position	Points	Position	Points	Position	Points
Race Finish Points	1	50	12	18	23	7
	2	40	13	17	24	6
	3	35	14	16	25	5
	4	32	15	15	26	5
	5	30	16	14	27	5
	6	28	17	13	28	5
	7	26	18	12	29	5
	8	24	19	11	30	5
	9	22	20	10	31	5
	10	20	21	9	32	5
	11	19	22	8	33	5
Leading At Least One Lap: 1 Point						
Most Laps Led: 2 Points						

12.6.1. Entrant/Driver Qualifications Points

12.6.1.1. INDYCAR shall award one point to the Entrant and Driver qualifying for the Pole Position

13. COMMERCIAL ACTIVITIES & AWARDS

13.1. Logo Display

13.1.1. All Members agree to comply with the INDY NXT Series Style Guide, including, without limitation, display of all required emblems on all uniforms, Cars and other equipment and/or use of all required equipment. The INDY NXT Series Style Guide can be accessed at epaddock.indycar.com.

13.2. Advertising

13.2.1. INDYCAR may regulate or deny the advertising of any product on equipment, apparel or otherwise in connection with a Member, INDYCAR, the NTT INDYCAR SERIES or any Event.

13.2.2. Advertising may not be displayed until it has been approved by INDYCAR. INDYCAR may disapprove advertising for any reason, including, without limitation, advertising which it determines is offensive, inappropriate, illegal, undignified, in conflict with any INDYCAR or Event Promoter sponsorship, potentially confusing or may detract from the interest in any Event and/or the integrity of INDYCAR and/or the INDY NXT Series.

13.2.3. INDYCAR may require a Member to agree in writing with a policy statement regarding advertising of a particular product.

13.2.4. Product advertising must comply with all Rules, including without limitation, size.

13.3. Title Sponsor

13.3.1. No Member shall grant any sponsorship or other promotional rights to any party for any products or services in the Title Sponsor Category (as defined below) unless approved in writing by the Title Sponsor. If any Member grants sponsorship or other promotional rights to any party that offer products and/or services in the Title Sponsor Category or are otherwise competitive with products and/or services offered by the Title Sponsor, such party shall activate its rights only with respect to its other separate business lines which are not in the Title Sponsor Category and not with respect to the Title Sponsor Category.

13.3.1.1. For purposes of this [Rule 13.3](#), Title Sponsor Category is defined as IT services and solutions which includes the following:

13.3.1.1.1. Application Services – full scope of end-to-end application capabilities for both custom and enterprise applications, including app development, modernization, testing, management and outsourcing.

13.3.1.1.2. Business Process Outsourcing – managing non-core business processes with industry specific platforms, robotic process automation, and straight-through processing to improve productivity.

13.3.1.1.3. Cloud Services –on-demand access to resources, via the internet, using servers or hybrid solutions.

13.3.1.1.4. Consulting Services – strategic business and IT consulting, managed security consulting and technical consulting that helps clients devise a strategy, build a roadmap and implement processes and systems that support long-term business advantage.

13.3.1.1.5. Data Center Services – deploying operational management, network services, disaster recovery with consulting, design, installation, consolidation, and relocation to reduce process cycle times and improve productivity.

13.3.1.1.6. Digital Business Services –enable new business models by leveraging technologies including analytics, mobile, customer engagement, block chain, cloud and the internet of things.

13.3.1.1.7. Dynamic Workplace Services – end-user outsourcing with workplace virtualization, custom apps, unified communications, field services, collaboration, managed mobility, and end-user analytics.

13.3.1.1.8. Network Services—connectivity solutions using centralized control and configured policies to route traffic along the most suitable connection. This capability boosts application performance and improves connectivity to cloud-based resources.

13.3.1.1.9. Security Services—services that secure your business across the entire information and communications technology stack and throughout the full security life cycle and limit and remove business disruption and data loss.

13.3.1.1.10. Competitors in the IT Services and Solutions category include, but are not limited, to the following (in alphabetical order): Accenture; Amazon; Atos; Automatic Data Processing; Capgemini; CGI; Cognizant; Deloitte; DXC; EY; Fujitsu; HCL Technologies; Hitachi; IBM; Infosys; KPMG International; Leidos; PwC; Tata Consultancy Services and Wipro.

13.3.2. Notwithstanding Rule 13.3.1, no Member shall be required to breach any existing agreement in effect as of January 15, 2019 and may continue to fulfill its obligations to such parties in accordance with the terms of such agreements, including any renewal rights contained in those agreements subject to the limitation that any such renewal shall not increase a third party's prominence in the Title Sponsor Category (i.e. visibility or sponsorship rights) with respect to the Member within the NTT INDYCAR SERIES.

13.3.3. INDYCAR will provide business exclusivity for all Bridgestone Americas companies, including but not limited to tires and retail automotive service, unless BATO and INDYCAR agree to waive the exclusivity for specific circumstances.

13.4. Product Use

13.4.1. A Member shall not make a false or potentially false public or private statement concerning any product used or said to have been used in any Event. An Entrant may be required to provide INDYCAR with an affidavit certifying product use. Display of an emblem on a Car or uniform does not constitute a statement concerning use.

13.4.2. INDYCAR may certify that a product was used at any Event(s). To be eligible to receive certification of product use, the product manufacturer must agree in writing to the following:

13.4.2.1. The product manufacturer must agree in writing to be bound by the Rules and must agree to be subject to penalty pursuant to the Rules.

13.4.2.2. Product manufacturers posting awards contingent on product use and the display of advertising during an Event must provide INDYCAR with a statement of the conditions at least 30 days prior to the Event. The product manufacturer shall provide INDYCAR with proof of award distribution in accordance with these conditions within 30 days of certification by INDYCAR of the product use.

13.4.2.3. Any advertisement of products and the related use of these products during an Event must be consistent with the facts as determined by INDYCAR and must not be likely to deceive, or mislead, the public.

13.4.2.4. INDYCAR may add or revoke requirements, as it deems appropriate.

13.5. Media

13.5.1. Testing

13.5.1.1. Members agree to provide a minimum of one (1) hour of media availability per on-Track Test Day.

13.5.2. Pre-Race Activities

13.5.2.1. Driver Autograph Sessions – INDYCAR may conduct one or more autograph sessions of Drivers during each Event.

13.5.2.2. Practice – Requested Drivers must attend post-practice media appearance.

13.5.2.3. Qualifications – Drivers must attend the following:

- Pole Qualifications media “bullpen” appearance.
- Pole winner photograph obligations.

Immediately following Qualifications, media center appearance for the drivers starting on the front row or any other requested drivers.

13.5.2.4. Pre-Race Ceremonies – Unless otherwise directed, the Drivers shall proceed to the Pre-Race stage and fully participate in Pre-Race ceremonies including without limitation any Driver introductions and/or Track laps.

13.5.3. Post-Race Activities – Unless otherwise directed, the top three finishers in the Race shall proceed to victory lane as instructed by INDYCAR and fully participate in post-Race ceremonies including without limitation, not removing, obscuring, or otherwise altering any sponsor recognition. Specifically, at a minimum, this includes the following:

13.5.3.1. The winning Driver must attend and participate in post-Race interviews in victory lane. The winning Driver and Car Owner of a Race agree to permit the display on the Car in victory lane, as designated by INDYCAR, at least one item from the Title Sponsor and one item from the Car’s sponsor as determined by INDYCAR, including size, location and placement of such item(s). The winning Driver and Entrant agrees to participate in a photograph session with the Event sponsor(s) and guests.

13.5.3.2. The 2nd through 5th place Drivers must stop in Pit Lane or such other area as designated by INDYCAR and participate in media interviews.

13.5.3.3. The 2nd and 3rd place Drivers must proceed to victory lane and join the Race winner in post-Race ceremonies. The top three finishers must wear INDYCAR provided hats in the following order: Firestone and INDY NXT by Firestone.

13.5.3.4. Immediately following victory lane ceremonies, the winning Driver, 2nd place Driver and 3rd place Driver must attend and participate in post-Race interviews in the media center.

13.5.3.5. Following the media center interviews, the winning Driver shall attend and participate in additional interviews, if requested by INDYCAR.

13.5.3.6. All other Drivers agree to attend and participate in the post-Race media center interview process, if requested by INDYCAR.

13.5.4. Championship – All Drivers and Entrants mathematically eligible to win the end of season Driver and/or Entrant point standings agree to attend and participate in activities as follows:

13.5.4.1. Race market for final Race: a media activity approximately four weeks prior to the end of season Event.

13.5.4.2. During the final five (5) Races: designated pre-Race and/or post-Race media requirements, including national media teleconferences, press conferences, satellite media tours and/or radio tours as directed by INDYCAR.

13.5.4.3. Championship Event(s) during Event week: media event(s) as designated by INDYCAR.

13.5.4.4. INDY NXT by Firestone Champion: a national media tour that could include a trip or trips to national media markets, if requested by INDYCAR.

13.5.4.5. Celebration – The winning Driver and Car owner must attend and participate in the celebration at such times and locations as designated by INDYCAR.

13.5.4.6. Championship: If Entrant wins the championship, it agrees to grant to INDYCAR or its designee the right to possess and use the winning Car for display during mutually agreed upon times of the celebration. Consideration for the above use of the winning Car is acknowledged as the opportunity to compete for awards for the on-Track Events and acceptance of the Entries

13.5.5. Penalties – INDYCAR shall determine whether a Member has failed to attend, failed to actively participate, or engaged in inappropriate conduct during a meeting or mandatory activity. The following penalties may apply:

- 13.5.5.1.** First Offense – \$5,000 and/or require attendance at an additional/substitute meeting and/or promotional appearances.
- 13.5.5.2.** Each Additional Violation – INDYCAR may double the fine, require attendance at additional/substitute meetings or activities.
- 13.5.5.3.** Whether in attendance or not, Members shall be charged with knowledge of the matters discussed at all meetings (whether mandatory or not). A Member and the Member's Entrant waive the right to review and/or appeal any penalties that may be assessed for any violation of the Rules if the Member was absent, did not actively participate, or engaged in inappropriate conduct at the meeting.
- 13.5.5.4.** Cellular telephones or wireless mobile devices may only be used for the purpose of taking notes during any meeting and/or activity unless approved by INDYCAR.

13.6. Awards

- 13.6.1.** Entrants and Drivers displaying the mandatory award sponsors and otherwise complying with the Rules may be eligible to earn awards.
- 13.6.2.** The distribution of all awards must be approved by INDYCAR.
- 13.6.3.** INDYCAR shall determine the eligibility, nature and amount of all awards for:
 - 13.6.3.1.** Each Event, and
 - 13.6.3.2.** End of season.
- 13.6.4.** Withholding
 - 13.6.4.1.** Offset – INDYCAR shall have the right to offset any amounts owed by a Member to INDYCAR, an Event Promoter or a Manufacturer against any award otherwise payable to the Member or the Member's Entrant. If INDYCAR receives notice that Member has failed to pay an Event Promoter or Manufacturer, INDYCAR shall have the right to pay the Event Promoter or Manufacturer directly after giving the Member a 48 (forty-eight) hour period to dispute the offset. Should the Member dispute the offset or in the event INDYCAR receives conflicting demands for such amounts, INDYCAR shall, at its option, be entitled to seek a court order to ascertain the rightful distribution of funds.
 - 13.6.4.2.** All awards may be withheld by INDYCAR in whole or in part, or denied in whole or in part, if INDYCAR determines in its discretion that any member of Entrant Group has failed in any way to comply with the terms and conditions of the Rules.
- 13.6.5.** Review – If a review is requested in accordance with Rule 10, affecting the distribution of an award, all awards so affected shall be forwarded to the INDYCAR office or in the case of monetary awards placed in an escrow account as directed by INDYCAR within five Business Days after the filing of the review, without obligation as to interest.

14. TECHNICAL SPECIFICATIONS

14.1. General

- 14.1.1. INDYCAR shall maintain a technical site on (IRIS) for Members to submit questions and INDYCAR to provide technical information or provide various technical updates when necessary.
- 14.1.2. Questions to be submitted and will be answered via IRIS. Modifications must be approved seven (7) days prior to the date of intended use.
- 14.1.3. All parts provided by an Approved Supplier must be used as supplied without modification unless otherwise approved by INDYCAR and stated in these Rules or in update bulletins.
- 14.1.4. Approved Suppliers must submit bulletins to INDYCAR for approval prior to releasing bulletins to Entrants. Once submitted bulletins are approved by INDYCAR, Members are subject to enforcement by INDYCAR.
- 14.1.5. All original Manufacturer identification markings and/or tags must remain as supplied.
- 14.1.6. Tape is not permitted as a single source of attachment for any component.
 - 14.1.6.1. At Events where garage structures are utilized, Entrants must roll Cars out from under roof when Engines are started.
- 14.1.7. Anodizing of parts is permitted.
- 14.1.8. Heating / Cooling No form of artificial heating or cooling may be used for any system, when the Car is outside its assigned tent or garage area, except towels applied to bodywork and Driver specific cooling devices.
- 14.1.9. Self-contained, battery powered electronics box cooling fans through the supplied electronic cooling inlet or direct application only. Must be submitted to INDYCAR via IRIS for approval.
- 14.1.10. Heat shielding other than fabric or sleeving must be submitted to INDYCAR via IRIS for approval.
- 14.1.11. Fabricated brackets to retain electronics or other parts must be submitted to INDYCAR via IRIS for approval.
- 14.1.12. Anti-rotational devices are permitted on pushrods and towlinks, provided they remain parallel to the mounting surface. Devices must be submitted to INDYCAR via IRIS for approval.
- 14.1.13. Officials reserve the right to seal any component(s).

14.2. Technical Inspection

- 14.2.1. The responsibility remains with the Entrants to make sure Cars conform to all Rules throughout the course of an Event. All Cars must complete safety inspection to be eligible for an Event. Officials may inspect any item for conformity of the Rules at any time. Completion of technical inspection does not guarantee against disqualification or other penalty if any violation is discovered during any subsequent inspection(s).
- 14.2.2. Officials may impound or confiscate a Car or part, equipment, item or data associated with a Car, Driver, Entry or Entrant.
- 14.2.3. Officials may examine any Car involved in a crash and determine if it's suitable for further participation and all Members shall cooperate in the preparation of damage reports, photographs, videotaping and impact recording analysis. Any Entrant refusing to follow the prescribed inspection procedures may be penalized and/or excluded from further participation in an Event.
- 14.2.4. A copy of all required inspection forms must be submitted to Officials for approval before the designated Events.
- 14.2.5. Decorative plating may not be used on any parts requiring magnetic inspection. All parts, which are painted, plated or coated, must be stripped before nondestructive testing and inspection.

14.3. Reference Planes and '0' Coordinates

- 14.3.1. All measurements shall be taken from the reference plane or '0' coordinates. These shall be established by Dallara and cannot be modified.
- 14.3.2. References will be measured using the following coordinates:
 - a) "X" coordinate is defined as the relative location fore and aft of the front face of the forward chassis bulkhead - "0" being the forward face of the chassis. These measurements will be referred to as +/- the "X" line, with (- negative) being forward.
 - b) "Y" coordinate is defined as the location laterally from the chassis centerline, Drivers right hand side being positive.
 - c) "Z" coordinate is defined as the location vertically with the bottom of the skid being 0 'Z', + (positive) being up.

- 14.3.3. The bottom of the skid establishes the "chassis reference plane." For purposes of technical inspection, the chassis reference plane will be one hard point manufactured from steel bolted to the bottom of the bellhousing in the specified location and an inspection frame placed on the chassis/nose bulkhead. The hard point shall be Ø1.500 inches and may not be shimmed or machined.

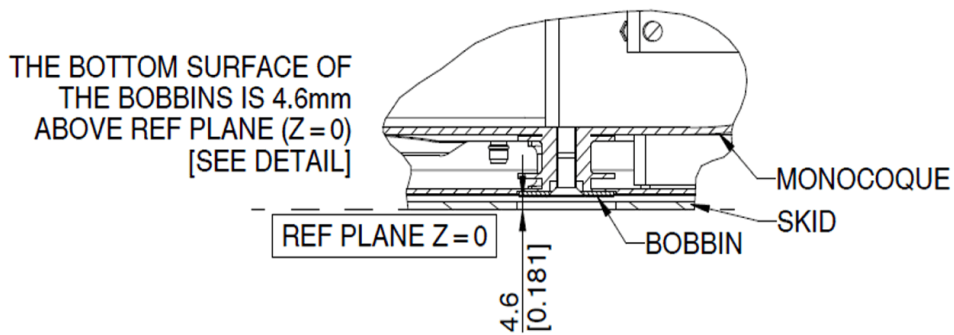

14.4. Car

Dimensions

14.4.1. All dimensions must remain within the following tolerances.

- a) Maximum underwing width - 73.0 inches
- b) Maximum body width - 63.0 inches
- c) Wheelbase - 116.5 - 117.5 inches
- d) Length - Road, street and short oval 196.929 +/- 0.250 inches
- e) Maximum offset - .500 inches

14.4.2. Front and Rear Track width and offset may be adjusted by shimming behind inboard suspension blocks to a maximum of 0.187" and provided the Manufacturer supplied mounting blocks and gearbox studs are used.

14.5. Wings & Wickers

14.5.1. Both front and rear wings must be run at all Events in the locations and configuration determined by Dallara. All references are measured from the reference plane, which is considered "0". All wickers, regardless of location, must be made from either carbon or aluminum and be a maximum 0.063" thick. Bolt or adjustment holes may be taped over.

14.5.2. Wickers may only be added to the locations shown in the diagram below. Each location is only permitted to have one wicker installed at any time.

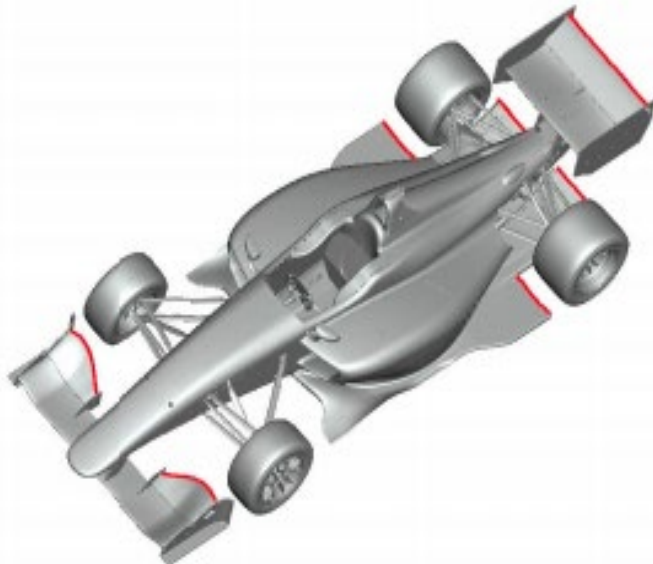

14.5.3. All wickers may be a maximum of 1.00" tall (measured as total height) and fastened 90 degrees to the mounting surface. Measure as total height with the exception of the underwing tunnel exit wicker.

14.5.4. Wickers must be parallel top surface to bottom surface and ends must be trimmed 90 degrees to the top surface. A 1 inch maximum radius is permitted.

14.5.5. Wickers on the underside of any location are not permitted.

14.5.6. Nut plates and additional bolt locations may be added for mounting purposes.

- 14.5.7. The underwing tunnel exit wicker may not exceed 17 inches in length measured from the tunnel exit sidewall inward, must be mounted to the vertical trailing edge surface and height is measure from the top surface of the underwing tunnel exit.
- 14.5.8. Front wing wickers may be full span in length.
- 14.5.9. Tire foot wickers may not exceed 15 inches in length measured from the outside edge inward.
- 14.5.10. Rear wing wickers may be full span in length.
- 14.5.11. The rear vertical face of all wing and tire foot wickers must be positioned at the trailing edge.
- 14.5.12. No painting, adhesive film or any other substance may be applied to the underside of the mainplanes. Any paint or adhesive film (except for decals) applied to the top surface of the mainplane or flap must extend to the trailing edge.
- 14.5.13. The front and rear pillars and/or mounts must be used as supplied. Pillars and mounts must be used per race location as specified by Dallara.

14.6. Wing Dimensions

- 14.6.1. All dimensions are measured in inches and must remain within the following tolerances.
- 14.6.2. Front wing mainplane angle:
 - a) Road, street and short ovals +5°- +3° (nose down)
- 14.6.3. Front wing mainplane minimum height:
 - a) Road, street and short ovals 2.50"
- 14.6.4. Front wing endplate minimum height:
 - a) Road, street and short ovals
 - a) Front Leading Edge 2.50"
 - b) Rear Trailing Edge -1.60"
- 14.6.5. Front wing overall width:
 - a) Road, street and short ovals maximum of 71.000" and a minimum of 70.700"
- 14.6.6. Rear wing mainplane angle:
 - a) Road, street and short ovals -2 to -2.5" (nose up)
- 14.6.7. Rear wing mainplane height (measured at the trailing edge):
 - a) Road, street and short ovals maximum of 28.400" and a minimum of 27.900"
- 14.6.8. Rear wing endplate height:
 - a) Road, street and short ovals maximum of 36.850" and a minimum of 36.350"
- 14.6.9. Rear wing overall width:
 - a) Road, street and short ovals maximum of 35.380" and a minimum of 35.080"

14.7. Underwing

- 14.7.1. The underwing height has a maximum of 1.400" and a minimum of 1.250"
- 14.7.2. The underwing is subject to deflection test loading of 50 pounds with a maximum deflection of 0.100"
- 14.7.3. The underwing tunnel exit height has a maximum of 6.360 inches and a minimum of 6.560 inches.
- 14.7.4. The underwing strakes must be used as supplied and as specified by Dallara.
- 14.7.5. Other than clear coat, no painting, tape, silicon, adhesive film, or any other substances are permitted on the bottom surface of the underwing except for filling or covering holes.

14.8. Skids

- 14.8.1. The skid plate must be made to the drawings as posted on ePaddock. The only approved skid materials are aluminum or phenolic and shall be a minimum thickness of (0.120" or 3mm) when new.

14.9. Aerodynamics

14.9.1. Oval Track Configurations

	Description	WWTR	MILWAUKEE	NASHVILLE
AERO & GEAR REQUIREMENTS	Louvre Panels	U	U	M
	Solid Exit Panels	M	M	U
	Rear Wing Angle	OPEN	OPEN	MAXIMUM 22°
	Rear Wing Wicker	———— PER RULE 14.5.3 ————		U
	Underwing Tunnel Exit Wicker	○	○	○
	Tire Foot Wicker	○	○	U
	4th, 29/31	○	○	M
	5th, 29/30	○	○	M
	6th, 24/24	○	○	M

M= Mandatory

○= Optional

U= Unapproved

14.9.2. The only permitted configurations are as defined by the IL15 aero manual. In the case of any conflict between the aero manual and Rule Book, the Rule Book shall take precedence.

14.9.3. Attachments or devices that are moveable or adjustable while the Car is in motion and which may affect airflow are not permitted.

14.9.4. All wings and bodywork are subject to deflection loads of 50 pounds with a maximum deflection of 0.100"

14.10. Bodywork

14.10.1. Fit and finish is permitted provided it does not alter the components internal or external shape in any way.

14.10.2. The leading edge of the sidepods are an integral part of the crash structure and must remain fastened to the chassis. Additionally, they may be glued if desired.

14.10.3. Providing there is no change to the intended shape or profile of the original part, tape may be applied to bodywork, chassis junctions, openings, rear wing pillar fairings and fasteners; with the following exceptions:

14.10.3.1. Nose camlock holes;

14.10.3.2. Tow bar holes;

14.10.3.3. Nose to chassis;

14.10.3.4. Shock cover to chassis;

14.10.3.5. Headrest to chassis split lines;

14.10.3.6. Engine cover suspension holes;

14.10.3.7. Rear wing pillars;

14.10.3.8. Rear wing mounts;

14.10.3.9. Engine cover and sidepod fasteners

14.11. Carbon Repairs

14.11.1. All repairs must conform to the Manufacturers original design criteria including weight +/-

14.11.2. Structural Repairs – Chassis, nose and attenuator structural repairs may only be made by Dallara. The Technical Director in his sole discretion will determine whether components are repairable or must be replaced, based on specific safety criteria. Once any component is deemed non-repairable the RFID tag number will be deleted from the Team's inventory and can no longer be used. The Technical passport as supplied by Dallara must be submitted to the Technical Director for all structural repairs.

14.11.3. All other carbon parts may be repaired, provided there is no change to the intended profile, position, orientation, stiffness or overall weight of the repaired part.

14.11.4. Remanufacturing of any component around the RFID tag is not permitted. Completely re-skinning or manufacturing a new part from a mold is not permitted.

14.11.5. Teams are permitted to repair or have components repaired provided they adhere to the following:

- a) All repairs must be declared to INDYCAR by the Team or repair station before returning to use.
- b) All repairs are subject to INDYCAR's approval.

14.12. Fasteners

14.12.1. All external fasteners must be used and remain in the locations as delivered. Tape or glue is not permitted as a single source of attachment for any component.

14.12.2. All fasteners including but not limited to body fasteners, washers, nuts, bolts, spacers and rod ends, may be individually sourced by Teams provided they are commercially available of the same size, type, material and design as originally provided by the approved supplier.

14.12.3. Installing nut plates on any non-mechanical is permitted as long as they serve no other purpose.

14.13. Inlet Shutters and Exit Panels

14.13.1. The right side may only be shuttered using the inlet shutter available from IPC (part #IPC-IL-20-01) The shutter may be trimmed at any of the five provided trimlines. Mounting brackets/flanges may be added provided they are not visible when viewed from the front and provide no other purpose.

14.13.2. The left side may only be shuttered on the front face of the radiator between the radiator and the radiator box. Mounting/strengthening flange(s) no wider than $\frac{3}{4}$ " of an inch may be used. Sealing of the shutter to the radiator with foam or rubber is permitted.

14.13.3. Shuttering of the intercooler is not permitted.

14.13.4. Shuttering of the gearbox cooler is not permitted.

14.13.5. The sidepod radiator exit panels must be used as supplied.

14.13.6. The louvered panels must be used at all road and street course events and the Iowa oval event. Taping or covering the louvers (top or bottom) is not permitted.

14.13.7. The solid exit panels must be used on ovals, except for the Iowa oval event.

14.14. Radiators/Coolers

14.14.1. Radiators and intercoolers must be used as supplied by Dallara.

14.14.2. Smoothing out internal welds is permitted provided there is no change to the intended shape.

14.14.3. Water, oil, and intercooler pipes must remain as supplied except for fitment related issues.

14.14.4. Bunges for heaters or bleed fittings may be welded to the inlet and outlet pipes.

14.14.5. Fabricated brackets with a maximum width of $\frac{3}{4}$ inches may be installed to retain the radiators in place of the ty wraps. Brackets must be submitted to INDYCAR via IRIS for approval.

14.15. Mirrors

14.15.1. Mirrors must be used as supplied by Dallara. The minimum glass dimension is 6.00" wide by 2.00" tall. No portion of the mirror lens may be recesses in the mirror housing by more than 0.250 inches. The standard Dallara mounting location for the lens may not be moved and the housing must be trimmed to comply with the 0.250 inch dimension.

14.16. Windscreen

14.16.1. Windscreens may not exceed 20.00" inches in length, 1 inch in height measured from the top surface of the cockpit rim or more than 0.125" inches thick. Windscreens must maintain the same height at all points excluding the last 6 inches which may be tapered.

14.17. Pedals

14.17.1. The pedal mounts have multiple adjustments and can be moved as required. Pedal pads may be modified or change for driver comfort, all changes must be submitted to INDYCAR via IRIS for approval. The INDYCAR throttle peddle part number IR1211C001 is an approved option.

14.17.2. Brake Pedal clevis must be used as supplied, approved part numbers are: IL1535048 and IR1235087

14.18. Electronics

14.18.1. Loom drawings are provided for the sole purpose of diagnosing issues, and all major repairs to the looms must be made by Cosworth. Components must be used as supplied without modification unless otherwise specified. The Centaurus 520 Power Controller (# 01L-610100) must have a 1.000inch cooling duct.

14.18.2. The following mandatory sensors must be used as supplied by Cosworth or Texense during all INDYCAR Events:

- a) Damper pots (4)
- b) Steering pot

- c) Wheel speed sensors (4)
- d) Brake pressure sensors
- e) Clutch pressure sensor (supplied by AER)
- f) Rain light
- g) Gear position sensor
- h) Gearbox temperature sensor
- i) Shift accumulator pressure sensor
- j) Throttle position sensor

14.18.3. Additional optional sensors approved for use during Race Events and Open Tests are:

- a) Pushrod load cells
- b) Laser ride height sensors
- c) 3 axis gyro
- d) Pitot tube and aero sensor
- e) Infrared brake temp sensors
- f) GPS (Maximum 10Hz)
- g) Expansion box
- h) Anti-roll bar position sensors
- i) TPMS system (Mandatory on Ovals, option for Road and Street courses)
- j) Brake master cylinder displacement
- k) Gearbox pressure sensor

14.18.4. Tire Pressure Monitoring Systems (TPMS) are mandatory on ovals their use is unrestricted during Events. BERUF1 and IZZE systems are the only approved supplier. TPMS systems may monitor pressure and temperature.

14.18.5. Steering Wheel - The steering wheel must be used as supplied. Changes are not permitted to buttons or switches. Modifications to the shift paddles and the use of additional personnel grips must be submitted to INDYCAR via IRIS for approval. Steering wheels must incorporate an INDYCAR approved quick disconnect.

14.18.6. The only battery approved for use is the ML20C provided by Braille. Cutting the battery cover into 2 pieces is permitted. The battery box cover and/or cooling duct is not required.

14.18.7. The external emergency switch must be clearly marked as outlined in the Style Guide.

14.18.8. The chassis loom connector to the radio adapter loom may be changed

14.18.9. Audible beep shift systems are not permitted.

14.18.10. Push to Pass Parameters

14.18.10.1. The total Push to Pass time per Race are as follows:

	Event	Total Time (Seconds)
Push To Pass Parameters	St. Petersburg	50
	Arlington	65
	Barber	65
	Indianapolis RC	65
	Detroit	50
	Road America	65
	Mid-Ohio	65
	Portland	65
	Laguna Seca	50

14.18.11. Push to Pass Restricted Periods. Push to Pass utilization is prohibited during the following Race Procedures:

- a) Race Starts, from the Engine start command to commence the parade and pace laps, until the Car crosses the alternate start/finish line for the first time after taking the initial green flag;
- b) Lapped-Car command blue, when INDYCAR orders a command blue to a Lapped-Car per Rule 7.2.5.1.

14.18.12. Competitor Responsibility and Prohibited Utilization. INDYCAR-controlled Push to Pass is prohibited during the periods identified in Rule 14.18.11 and it is the sole responsibility of Competitors to ensure that Push to Pass is not utilized during any period where prohibited. Any successful utilization of Push to Pass during such periods, regardless of the INDYCAR signal status, is prohibited and subject to penalty per Rule 9.2.2.

14.18.13. Determination and Enforcement. INDYCAR and IOI shall determine any utilization of Push to Pass using any of the following sources: ECU data, timing data, and/or any other available telemetry or electronic data. Any such offending data shall be deemed sufficient evidence of a violation.

14.19. In-Car Systems (collectively, “Systems”)

14.19.1. The following systems must be installed, maintained, and operational during on-Track activity at Events:

- a) Marshalling System — Rule 7.1.7.3
- b) SMT Broadcast Telemetry System — Rule 14.20.3
- c) Timing System Components — Rule 14.21
- d) Impact Recorders – Rule 14.22
- e) Cameras – Rule 14.23

14.19.2. Competitor Responsibility. Competitors must ensure that all systems in Rule 14.19.1 are correctly installed in the specified configuration and location and are functioning properly for on-Track activities. Improper installation, unauthorized modification, failure to power or activate the system, and/or failure to complete pre-session functional verification are subject to penalty. Completion of technical inspection does not relieve Competitors of this ongoing responsibility throughout the Event.

14.19.3. Failure Notification. INDYCAR or system vendors may notify a Competitor of a system malfunction. The Competitor must acknowledge such notification and take immediate corrective action as directed by INDYCAR or system vendors.

14.19.4. Excluded Failures. The following system failures shall not be subject to penalty:

- 14.19.4.1.** Failure of vendor-supplied hardware on a Car; and
- 14.19.4.2.** Temporary signal loss caused by environmental conditions including but not limited to track tunnels, overhead structures, garage areas, or other physical signal obstructions where the system is otherwise functioning correctly.

14.19.5. INDYCAR will determine whether a system failure is attributable to lack of Competitor responsibility, vendor equipment, or environmental conditions. INDYCAR's decision is not subject to review and/or appeal.

14.20. Telemetry

14.20.1. All Entrants shall install, operate, use and permit the use of broadcast telemetry equipment, video equipment, sound equipment, data and other positioning informational systems as directed by INDYCAR. Entrants shall not install any of the above systems unless directed by INDYCAR.

14.20.2. INDYCAR shall own all telemetry; video, sound, data and other information generated or collected as described and control the use and dissemination.

14.20.3. SMT Broadcast Telemetry System

14.20.3.1. The SMT broadcast telemetry system must be installed in the INDYCAR-specified location with all modules, harnesses, and antennas as supplied. The system is GPS-based and provides data for Event broadcast and operations.

14.20.3.2. The SMT system must be operational and transmitting during all on-Track activity. Competitors must ensure the system is powered, active, and acquiring signal before the Car proceeds on-Track.

14.21. Timing System Components

14.21.1. The timing system components, which include the transponder and X2 link, must be operational during all on-Track activity and installed in the designated location as supplied by INDYCAR.

14.22. Timing Transponder

14.22.1. The timing transponder must be used in the designated location as supplied by INDYCAR.

14.23. Impact Recorders

14.23.1. Impact Recorders – All Cars must make provisions for the installation of an impact recorder.

14.23.1.1. The impact recorder supplied by INDYCAR and used without modification, must be securely bolted using four (4) bolts to the main chassis structure in the Dallara/INDYCAR specified location.

14.23.1.2. The impact recorder download block and indicator lights must be located in the Dallara/INDYCAR specified location.

14.24. Cameras

14.24.1. In-car cameras – Upon INDYCARs request on-board cameras must be used as supplied by Broadcast sports INC.If INDYCAR does not request an on-board camera be used, dummy camera equipment must be used included wiring, camera housing HD transmitter ballast and HDDR ballast.

14.24.2. On-Board Video Equipment – Entrants must utilize the AiM Smarty Cam GP HD 2.2 or 2.3 onboard camera during all on-track activities. The role hoop camera housing must be mounted per Dallara in the designated location. Data must be per the INDYCAR Technical Memo. Entrants must set the AiM on-board camera to have a stop record delay of at least 2 minutes. The following mounting guidelines must be adhered to:

- a) Cameras may be installed inside of the carbon shroud or mounted to a plate which may not protrude more than 4 inches forward of the role hoop.
- b) Cameras must be mounted on the centerline of the chassis, except when running a television camera - they must be moved or removed so the television camera has an unobstructed view.

14.25. Suspension

14.25.1. All suspension components must be used as supplied. The Dallara “FLWB Anti-intrusion Plate” must be used at all times. The configuration of the mounting blocks are a team's choice, provided only Dallara supplied components are used. Heat shielding added to the left rear wishbone has a maximum thickness of .800 inches and maximum width of 2.750 inches.

14.25.2. Toe, camber and castor may be adjusted, provided they are within Dallara's suspension specifications. When a tire Manufacturer provides a maximum camber, this will supersede Dallara's maximum adjustment. The rulebook will supersede all. The mandated maximum cambers are as follows:

Short Ovals

14.25.3. Ride Control – the use of front and rear ride control (example – 3rd springs, dampers) systems are not permitted.

14.25.4. Anti-Roll Bars – Anti-roll bars must be used as supplied by Dallara. The Cockpit roll bar adjusters may not be moved.

14.25.5. Rockers – Rockers must be used as supplied by Dallara. Attachment of nut plates as specified by Dallara are approved.

14.25.6. Steering – Only the Dallara supplied rack and pinion options and parts may be used.

- a) The rack bar and pinions may be de-burred, shot peened or polished.
- b) A 0.125” diameter hole may be drilled for purposes of installing an alignment pin.

14.25.7. Weight jackers – Weight jackers are not permitted.

14.25.8. Uprights – Uprights and upright parts must be used as supplied by Dallara. Shimming for the sole purpose of bearing preload is permitted. A thrust washer between the barring face and the hub retaining nut is permitted provided it does not exceed .050 inches.

14.25.9. A thrust washer between the barring face and the hub retaining nut is permitted provided it does not exceed .050 inches.

14.25.9.1. The front bearing inner races may be reduced by no more than 0.005 inches per side for the sole purpose of installing a shim for bearing preload.

14.25.9.2. The rear bearing spacer may be ground for bearing preload.

14.25.9.3. Remming or polishing of the bearings is permitted provided the intended shape remains as supplied.

14.26. Brakes and Ducts

14.26.1. Only PFC brake parts as supplied by Dallara are approved - including discs, pads, disc bells and calipers.

14.26.2. Disc specifications are 309mm x 28mm with a 17.5mm air gap which must remain open. Slots on the face of the disc must remain visible. The minimum disc thickness is 26.0 millimeters.

14.26.3. Brake calipers must be used as supplied, including seals. Caliper springs must remain in at all times. Any devices designed to push or pull back pistons (other than knock back springs) are not permitted.

14.26.4. There are two brake pad compounds, PFC 11 & 13. Pads must be used as supplied without modification. Pads must not be siliconed to the pistons. The minimum pad thickness is 9.5 millimeters.

14.26.5. Master cylinders are a Team-sourced item. Modifications to any part of the car to accept a master cylinder is not permitted. A return spring may be installed on the master cylinder if desired approved by INDYCAR via IRIS.

14.26.6. Brake ducts – The brake ducts must be used as supplied without modification. Tape or a flat panel are the only approved method for regulating airflow into the brake ducts. Flat panels may be fastened or permanently mounted provided they have no more than a 0.500-inch return, which is for the sole purpose of fastening. Brake ducts are optional for all Events. Brake ducts may be trimmed for hardware clearance to allow the upright and brake duct to be installed as an assembly.

14.27. Dampers and Springs

14.27.1. The approved damper is the Dynamic DSSV 1435 EVO. Dampers must be run without modification as supplied by the Manufacturer.

14.27.2. Dampers are sealed and may only be rebuilt by the Manufacturer.

14.27.3. Packers and bump rubbers are permitted.

14.27.4. Dampers must be externally adjustable only and cannot be adjusted by the driver.

14.27.5. Hydraulic or bearing spring perches are permitted provided they are approved by INDYCAR via IRIS.

14.27.6. Each corner must have one damper and one conventional spring only. Each spring must be comprised of round steel wire. Closed or ground ends are allowed.

14.27.7. Slotting of the droop limiters to assist with damper/spring changes is permitted.

14.28. Driveshafts & Hubs

14.28.1. Only parts provided by Dallara are permitted. These must be used as supplied without modification. The only approved wheel locking system is the Dallara spring loaded retractable assembly.

14.29. Energy Management System (EMS)

14.29.1. EMS must be used as supplied by Dallara and approved by INDYCAR.

14.29.2. All mounting points must be free of sharp edges.

14.29.3. EMS must be replaced if damaged or as required by INDYCAR.

14.29.4. EMS must be covered with an approved, protective shield made from carbon. The covers have a maximum width of 2.600 inches and maximum thickness of .800 inches (including the suspension). The length is open to Team discretion. The covers must be mounted parallel to the wishbone and must be as tight to the wishbone as possible.

14.29.5. Rear Wing – Rear Wing EMS cover must be parallel to the wing cover and have a maximum thickness of .700 inches.

14.30. Wheels

14.30.1. Rotiform (Motegi) are the only approved wheel Manufacturer.

14.30.1.1. Fronts – R630510CL408IL1 / R630510CL408IL1ANO

14.30.1.2. Rears – R630514CL418NIL1 / R630514CL418NIL1AN

14.31. Car Weight and Driver Equivalency Weight

14.31.1. The minimum weight shall include the car in ready to compete conditions excluding driver and driver equivalency weight.

a) Road/Street Events 1405 pounds

b) Short Oval Events 1405 pounds

14.31.2. The only approved ballast locations are the keel and skids.

14.31.3. All Drivers will be ballasted to a weight of 170 pounds. Any Driver weighing less must add weight (up to a maximum of 35 pounds) to the Car in the location provided by Dallara. This shall be known as the Driver equivalency weight. All ballast shall be installed with a Series representative present, who shall apply a seal once fitted.

- a) Any Driver weighing more than 170 pounds will be permitted to reduce the overall weight of the Car to help achieve the Driver equivalency weight.

14.31.4. Driver Equivalency Weight

14.31.4.1. INDYCAR specifies the Driver Equivalency Weight. INDYCAR shall notify each Entrant of its Driver Equivalency Weight.

14.31.4.2. Driver Equivalency Weight must bring the combined weight of the Driver and Driver ballast to 165 pounds.

14.31.4.3. INDYCAR may weigh any Driver and adjust the Driver ballast accordingly.

14.31.4.4. Drivers over 170 pounds are allowed a Car weight reduction equal to the amount the Driver exceeds 165 pounds.

14.31.4.5. The Driver ballast weight tolerance is 0.00 to + 1.00 pounds. The Driver Equivalency Weight must be installed and secured in the designed location forward of the seatback. This location may only be used for Driver ballast.

14.31.4.5.1. Drivers requiring 35 pounds or less of Driver ballast must have all ballast installed in the seatback location.

14.31.4.5.2. Drivers requiring 36 pounds or more of Driver ballast must have 35 pounds of ballast installed in the seatback location. The remaining required ballast may be installed in the keel ballast location or may be achieved by utilizing aluminum skids as follows:

- b) Front skid = 1 pound of ballast
- c) Middle skid = 3 pounds of ballast
- d) Rear skid = 3 pounds of ballast

14.31.4.6. The Driver Equivalency Weight must be a hard-dense metal.

14.31.4.7. Violation of this Rule may result in a minimum \$100,000 fine and/or other penalties.

14.31.4.8. All Drivers are reweighed at technical inspection within fifteen (15) minutes after completion of practice session one (1) of a Race Event. Drivers must wear the following personal safety equipment: uniform, underwear (top and bottom), socks, and shoes.

14.31.4.8.1. A Driver late for weigh in loses five (5) minutes from the end of the next practice session.

14.31.4.8.2. A Driver failing to appear for weigh in may not participate in practice and/or Qualifications until he/she has completed the weigh in.

14.31.4.9. Driver ballast changes are subject to the following:

14.31.4.9.1. A Driver weight change of plus or minus 3 pounds: Car and/or Driver weight will remain unchanged, and Entrants may not change their Driver ballast.

14.31.4.9.2. A Driver weight change of more than plus or minus 3 pounds: Entrants must change their Driver ballast before the next on-track session.

14.31.5. A Driver weight change of more than plus or minus 7 pounds: Entrants may be subject to penalty

14.32. Fuel & Fuel System

14.32.1. The only approved fuel is VP MS100. Fuel must be stored and used at ambient temperature and additives may not be used. Fuel is subject to testing at any time. Detailed guidelines on correct handling and storage of fuel are provided in the AER – P63 engine user manual.

14.32.2. The fuel system must remain as supplied by Dallara, this includes the fuel pump and filter specifications. Modifications may be made to the collector pot to allow 3 lift pumps to run simultaneously. All modifications must be submitted to INDYCAR via IRIS for approval. Fuel pickups may be moved and mounted as necessary.

14.32.3. Plumbing of fuel cell lines is free provided the internal hose diameters are not changed. Each engine is provided with a proprietary fuel line which cannot be changed. This hose must remain fitted to the engine fuel rail and be connected directly to the self-sealing breakaway valve. The fuel cell check valve/vent must have a line that exists at the rear of the car no less than 1.000 inches past the end of the underwing.

14.32.4. A lanyard secured self-sealing breakaway valve must be used on the supply line.

14.32.5. It must be possible to take a sample of fuel from a car at any time during an Event. The fuel temperature must be no more than 5 degrees below ambient temperature.

14.32.6. The only approved method for adding fuel is through a closed loop dry-break system. A crew member must be in attendance with a fire extinguisher.

14.33. Exhaust

14.33.1. The exhaust system must be used as supplied by SST Technology or HPI without modification. The turbo tailpipe extension is mandatory and must be supplied by HPI.

14.34. Clutch Assembly

14.34.1. Tilton is the only approved clutch supplier. Either a 3 or 4 plate clutch may be used. Part numbers are:

- a) 3 plate: #6513HSG-P
- b) 4 plate: #6514HSG-P

14.34.2. The clutch master cylinder is a Team sourced item - the Manufacturer is not mandated.

14.35. Hoses & Fittings

- 14.35.1. Turbo oil supply line (AN-3) and scavenge lines (AN-4 & AN-6) are AER parts. Teams must only use lines supplied by AER.
- 14.35.2. Turbo cooling lines, supply and return (AN-6) are AER parts. Teams must only use lines supplied by AER.
- 14.35.3. Oil scavenge lines (to and from the cooler) must not be reduced in internal diameter from the original (AN-12) lines.

14.36. Gearbox & Bellhousing

- 14.36.1. Use of the Xtrac gearbox system as supplied by Dallara is mandatory.
- 14.36.2. The gearbox installed angle is minus 0.10 degrees to 0.10 degrees relative to the '0' line.
- 14.36.3. Coatings of any kind are not permitted.
- 14.36.4. Remming of gearbox components is permitted provided the intended shapes remain as supplied.
- 14.36.5. ESA shifter 1399-932-1B-0001 (As supplied by Xtrac) is the only approved shift mechanism and must be used as supplied.
- 14.36.6. The gearbox must maintain all six (6) fully meshed gears during an on-Track Event. Reverse gear must be operational throughout all on-Track Events.
- 14.36.7. Differential – 1414-949-000A The friction and drive surface stack may be rearranged, provided eight inner plates and eight outer plates are used at all times. Shimming for preload purposes is permitted. The Diff Blocker 1414-453-000A must be used as supplied on all Ovals.
- 14.36.8. Accessories – Filters, screens and magnetic plugs are allowed provided they serve no other purposes.
- 14.36.9. Bellhousing – The bellhousing must be used as designed and supplied without modification.
- 14.36.10. The starter motor as supplied by Dallara is the only approved system for use.
- 14.36.11. Gearbox heaters may be used in the Teams tent or garage area only.
- 14.36.12. The carbon quick lift bracket supplied by Dallara is mandatory.
- 14.36.13. The only approved ratios, ramps and final drives are as supplied by Xtrac.
- 14.36.14. The only approved gearbox oil is XL-1 (Part number: 190-0395) as supplied by Xtrac.

14.37. Engine

- 14.37.1. The engine as supplied by the Manufacturer must be used without any modification. Any variation from specifications regarding installation, oil and filters, fuel, water, turbo charger, exhaust or waste gate and boost box may result in loss of championship points and a fine not to exceed \$25,000. Teams are to follow the operating manual as provided by the Engine Manufacturer as well as adhere to the conditions set forth in the Engine Lease Agreement"
- 14.37.2. The Series may confiscate any Engine or component(s), take fluid samples, such as oil and water or request further analysis at any time.
- 14.37.3. The In-Season Engine Mileage allowance is 5,000 miles to include all Race Events and Series Open Tests.
- 14.37.4. All engine changes and/or repairs must be approved by INDYCAR in conjunction with the Engine Manufacturer.
- 14.37.5. The engines alternator and drive belts must be connected at all times.
- 14.37.6. The ECU is controlled, administered and provided by the Engine Manufacturer. Any software changes will take place under the direction of INDYCAR.
- 14.37.7. Trunions may be shimmed for installation purposes and heat reduction coatings are permitted.

14.38. Turbo & Wastegates

- 14.38.1. Turbo chargers are provided by the engine supplier (AER). These are the only turbo chargers approved and must be used without modification. The air inlet bellmouth is provided by the engine supplier (AER) and must remain sealed to the turbocharger.
- 14.38.2. Waste gates must be used as supplied.

15. TIRES

15.1. General

- 15.1.1. Only Tires supplied by Firestone and approved by INDYCAR may be used. Each Tire must be used in its specified location.
 - 15.1.1.1. Schrader valves must be used as supplied by Firestone.
 - 15.1.1.2. Tire pressure bleeding must be done manually, through the schrader valve, and only while the car is stationary.
 - 15.1.1.3. Valve caps must be used during all on-Track activity and must provide an air-tight seal.
 - 15.1.1.4. Valve stems are open provided there is no modification to the wheel.
- 15.1.2. Tire pressures must comply with the Manufacturers recommended guidelines.
- 15.1.3. Tires are assigned to a specific Entrant and may not be sold, traded or otherwise reassigned, given or transferred to any other Entrant.
- 15.1.4. Tires may not be changed on a Car once the Car is in its position in the Starting Lineup on the Grid without INDYCAR approval.
- 15.1.5. Tire warmers are not allowed.
- 15.1.6. No substance may be applied to the Tires.
- 15.1.7. Only nitrogen or compressed air may be used to inflate Tires.
- 15.1.8. Pulling a vacuum on mounted Tires is not permitted.
- 15.1.9. Replacement Tires: Require prior INDYCAR approval.
- 15.1.10. Each Entrant is permitted the use of Tires as designated in the chart below.
 - 15.1.10.1. The carryover set(s) may be used in all practices preceding Qualifications. Carryover sets must be returned prior to Qualifications.
 - 15.1.10.2. Cars will not utilize carryover tires at Road America.
 - 15.1.10.3. Ovals
 - 15.1.10.3.1. One (1) carryover set from each Open Test to be used at same venue's race event.
- 15.1.11. Qualifications
 - 15.1.11.1. Only one set of tires may be used during Qualifications. This set of tires must be new/unused. Penalty for tire changes during Qualifications or between Qualifications and the Race are as follows...
 - 15.1.11.1.1. Tire changes with prior INDYCAR approval may result with the penalized car being moved to the rear of the starting lineup per rule 8.1.9.6
 - 15.1.11.1.2. Tire changes without prior INDYCAR approval will result in the penalized car being moved to the rear of the starting lineup per rule 8.1.9.6 and a minimum of a drive thru penalty.
- 15.1.12. Race
 - 15.1.12.1. For single Race Events, Entrants may start the race on either new or used tires.
 - 15.1.12.2. For double-header Race Events, each Entrant is required to start one of the two races on the same set of tires used during Qualifications.
 - 15.1.12.2.1. Only damaged tire(s) may be replaced. Damaged tire(s) may only be replaced with used tires. Damaged tire(s) must be presented to Technical Inspection post-race for verification.
 - 15.1.12.2.2. Tire(s) replaced during the race are subject to a minimum one (1) lap penalty.

15.2. Tire Allotments

15.2.1. Each Entrant is allowed the following:

		Event Venue	New Sets	Carryover Sets	CO from Event
Tire Allotments		St. Petersburg	3	2	Miami Group Test
		Arlington	3	2	St. Petersburg Race
		Barber (x2)	3	2	Arlington Race
		Nashville Open Test	2	0	None
		Mid-Ohio Group Test	2	Unlimited	Saved Sets
		WWTR Open Test	2	0	None
		Indianapolis RC (x2)	3	2	Barber Race
		Detroit	3	2	Indianapolis RC Race
		WWTR	3	1	WWTR Open Test
		Road America (x2)	3	1	Saved Sets
		Milwaukee Open Test	2	2	WWTR Race
		Mid-Ohio (x2)	3	1	Detroit Race
		Nashville	3	1	Nashville Open Test
		Portland	3	2	Mid-Ohio Race (1) Detroit Race (1)
		Milwaukee	3	1	Milwaukee Open Test
		Laguna Seca (x2)	3	2	Portland Race

**Oval carryovers only permitted during the first 10min of Practice 1.*

15.3. Road / Street Course Tires

15.3.1. Wet Tires may only be used with INDYCAR approval. Including all testing.

15.3.2. Team transported wet tires must be used before Firestone transported wet tires may be used.

15.3.2.1. Practice:

15.3.2.1.1. Wet Tires may only be used when wet conditions exist and approved by INDYCAR.

15.3.2.2. Qualifications:

15.3.2.2.1. Wet Tires may only be used when wet conditions exist and approved by INDYCAR.

15.3.2.3. Race:

15.3.2.3.1. If INDYCAR declares a wet start, Cars must complete one (1) official lap on wet Tires which must start under a green flag. The lap may be completed in Pit Lane even if the Car is pitted before the Start/Finish Line.

15.4. Replacement Tires

15.4.1. Replacement tires require prior INDYCAR approval.

15.4.1.1. A replacement tire will only be allotted when the tire being replaced is returned to the Tire Mounting Area.

15.4.1.2. .Allotment tires are only available during INDYCAR-sanctioned Events.

16. EQUIPMENT & GARAGES

16.1. Pit Lane Fire Equipment

- 16.1.1. The Entrant must have a fully charged ten (10) pound water fire extinguisher in the Car's pit area. A gauge must be attached to each fire extinguisher. The mixture must contain six percent (6%) Firebull.
- 16.1.2. Each Entrant must have a minimum of two (2) open containers of water in the Entrant's pit area each with a capacity of five (5) gallons.
- 16.1.3. Each Entrant must have a two (2) pound dry chemical extinguisher in the Entrant's pit area.

16.2. Equipment

- 16.2.1. All equipment must remain inside the Entrants designated Pit Box on the cold side of the pit wall and the fire lane must remain clear at all times.
- 16.2.2. All nitrogen bottles must be kept securely fastened in all locations, including common storage areas, and have a cage device or other container approved by INDYCAR to protect all valves and regulators. All nitrogen bottles must be returned to the designated location and secured at the conclusion of each on-Track Event.
- 16.2.3. The maximum height of the scoring stand is 84.000 inches measured from the ground to the top of the stand excluding awning. The maximum surface area of an awning is 85 square feet in plan view and be no more than 120.000 inches in height measured from the ground. INDYCAR may determine if an Entrant may use an awning at a particular facility. Scoring stands using wheels or castors must be chocked or secured from moving. Awnings, flags, umbrellas or shields may be used, provided they do not block spectator viewing.
- 16.2.4. Paint or other permanent markings may not be used in the garage, on the Pit Lane surface or on the pit wall.

16.3. Garage

- 16.3.1. INDYCAR reserves the right to assign transporter parking, garages and Pit Boxes.
- 16.3.2. If garages are available, Entries may receive one (1) garage per Entry.
 - 16.3.2.1. Each Entry will receive a minimum space of 12 feet in width for truck parking.
- 16.3.3. If available, Manufacturers may receive a designated amount of space in the garage area.
- 16.3.4. If garages are not available, each Entrant shall receive a maximum 30 feet wide parking location in the garage area to use as a garage for the transporter and tent/awning, unless otherwise noted.
- 16.3.5. Entrant agrees to reimburse Event Promoter for the cost of repairing any damage to the garage area that occurs during occupancy by the Entrant.
- 16.3.6. Tents will not be permitted to extend beyond the rear of the trailer or front bumper of the tractor.
- 16.3.7. Entrants must submit a diagram of their tent and transporter footprint layout by November 15th of the year prior to the first event and seven (7) days prior for any subsequent changes for INDYCAR approval.
- 16.3.8. Tailgate safety cables are mandatory and must be approved by INDYCAR.

16.4. Covers

- 16.4.1. Teams are permitted to utilize wall systems within their garage or awning areas. If the wall system exceeds 36 inches in height, a diagram of the wall system must be submitted to INDYCAR via IRIS for prior approval. All wall systems must adhere to the following guidelines:
 - 16.4.1.1. Garages
 - 16.4.1.1.1. The wall system may only be placed at the front of the garage.
 - 16.4.1.1.2. Support walls that sit 90 degrees to the front wall must not exceed four (4) feet in length.
 - 16.4.1.1.3. Wall systems may not be used when there is a dedicated walkway down the center of the garage structure.
 - 16.4.1.1.4. Wall systems must be removed at any time if requested by INDYCAR.
 - 16.4.1.2. Awning
 - 16.4.1.2.1. Wall systems may be used on all sides except the ends or sides where spectators are permitted.
- 16.4.2. During the entire Event, no screen, cover or other obstruction may be intentionally placed to obscure any part of a Car.
- 16.4.3. In addition to the above the following are specifically not permitted;
 - a) Engine, gearbox or radiator covers while Engines are being changed or moved around the garage;
 - b) Covers over spare wings;
 - c) Parts such as (but not limited to) spare floors, fuel rigs or toolboxes may not be used as an intentional obstruction.
- 16.4.4. Rain covers may be used during inclement weather conditions. No other form of cover may be used.
- 16.4.5. Covers which are placed over damaged Cars or components are permitted.

17. SAFETY

17.1. General

17.1.1. Safety Policy - While INDYCAR seeks to maintain safe conditions for Competitors and others taking into account all aspects of the Event, Members recognize that conditions may not be safe and can be affected by human error. At any Event, each Member acknowledges and agrees that racing is a hazardous activity and each Member's involvement and/or participation is with expressed assumption of this risk.

17.1.1.1. While acknowledging the inherent risk of racing to Competitors and other Members involved and/or participating in an Event, Members are personally responsible for their own safety, for the safety of each Member of Member Group and for the safety of their racing equipment. No Event Promoter, INDYCAR, or any Manufacturer, or other Member is responsible for the adequacy of any Member's racing equipment or racing activity to accomplish this purpose. No Event Promoter, INDYCAR, or any Manufacturer or other Member makes any representation, express warranty, implied warranty or covenant that safety equipment and/or personnel will prevent or reduce the Member's risk or extent of injury in any Event.

17.1.1.2. INDYCAR may take any action including canceling, postponing, temporarily stopping or delaying an Event, if INDYCAR determines that basic safety requires such action. INDYCAR may order off the Track any Member or Car that INDYCAR determines constitutes a hazard. INDYCAR may, prohibit any Member or Member's equipment from entering or continuing in an Event. Except as provided in [Rule 10.2](#), none of such decisions during an Event may be reviewed and/or appealed. In the event a Driver is ordered off the Track due solely to driving performance, the Entrant may replace the Driver with a Driver approved by INDYCAR and continue in the Event pursuant to [Rule 4](#).

17.1.2. Medical/Rescue Requirements and Injury Reports

17.1.2.1. A Driver may be required to demonstrate ability to exit the Car within eight (8) seconds to INDYCAR's satisfaction and by a method as determined by INDYCAR.

17.1.2.2. A Driver involved in a crash or injured in an incident must report to the medical center or as directed by INDYCAR and may neither continue in the Event nor participate in future Events without clearance from INDYCAR.

17.1.3. Biomedical Research and Device Testing Policy – All Members must comply with INDYCAR's Biomedical Research and Device Testing Policy available from ePaddock.

17.1.4. Safety Inspections – INDYCAR may inspect any equipment prior to each Event and re-inspect equipment at any time including, without limitation, before, during or after each Event. An Entrant may be required to replace without limitation seats, seat belts, helmets, headrests, head restraint systems and other equipment at any time, as determined by INDYCAR.

17.1.5. Personal Safety Equipment

17.1.5.1. Drivers – All Drivers must wear:

17.1.5.1.1. Fire resistant one-piece uniform conforming to SFI 3.4/5, FIA 8856-2000 or FIA 8856-2018 specifications; and

17.1.5.1.2. Fire resistant socks, shoes, gloves, head sock and underwear (long-sleeve tops and full-length bottoms) conforming to SFI 3.3, FIA 8856-2000 or FIA 8856-2018 specifications.

17.1.5.1.3. All removable dental appliances, chewing gum, rings, watches and other jewelry and comparable items should be removed before a Driver participates in any on-Track Event.

17.1.5.1.4. Helmets - All Drivers must wear safety helmets designed specifically for automobile racing that meet or exceed the FIA 8860-2018, or FIA 8860-2018ABP specification. Helmets must be spherical in shape and be fitted with a face shield that has an INDYCAR-approved positive latching mechanism designed to keep the shield down in the event of a crash. Aerodynamic devices must not protrude more than 0.250 inches from the surface outside of the shaded area shown below. Inside the shaded area, a 0.500-inch-high device is allowed. Flat back designs are not permitted. All helmets must be fitted with the INDYCAR approved removal system.



17.1.5.1.4.1. The FIA 8860-2018 helmet specification requires that the visor shall be fitted with a reinforcement panel in accordance with the 2011 F1 VISOR REINFORCEMENT PANEL FOR FIA 8860 HELMET specification. The original visor, before the reinforcement panel is fitted, shall be certified with the helmet to FIA 8860-2018 specification. The FIA8860-2018ABP specification does not require a visor strip.

17.1.5.1.5. All helmets must be inspected and approved by INDYCAR before use and are subject to confiscation and re-inspection by INDYCAR at any time, including, without limitation, before, during or after each Event. INDYCAR shall affix stickers to the helmets signifying approval for use. At any time, including, without limitation before, during or after each Event, INDYCAR may remove the approval stickers and require the helmets to be re-inspected and refurbished by a certified helmet manufacturer before INDYCAR will consider them for re-approval. The helmet manufacturer must submit to INDYCAR documentation stating the refurbished helmet is approved for use in competition in accordance with the Rules.

17.1.5.1.6. Head Restraint Systems – INDYCAR requires the use of head restraint systems. Head restraint systems must meet or exceed FIA 8858-2010 certifications and be approved by INDYCAR.

17.1.5.1.6.1. All head restraint systems must be inspected and approved by INDYCAR before use and are subject to confiscation and re-inspection by INDYCAR at any time, including, without limitation, before, during or after each Event. INDYCAR shall affix approval stickers to each head restraint system signifying approval for use. At any time, including, without limitation before, during or after each Event, INDYCAR may remove the approval stickers and require the head restraint system to be re-inspected and refurbished by the FIA certified head restraint system manufacturer before INDYCAR will consider it for re-approval. The head restraint system manufacturer must submit to INDYCAR documentation stating that the head restraint system is approved by FIA for use in competition in accordance with the Rules. Head restraint systems that extend over the upper back and require chest restraints, are not permitted.

17.1.5.1.7. Earpieces – All Drivers must wear INDYCAR-supplied instrumented earpieces. Earpieces must be presented to INDYCAR for testing before each Event and upon request. Repair and/or replacement of the earpieces may be at the Driver's expense.

17.1.6. INDYCAR may examine any Car involved in a crash and determine if it is suitable for further participation and all Members shall cooperate in the preparation of damage reports, photographs, videotaping and impact recording analysis. INDYCAR will inspect the items. Any item that does not successfully complete inspection must be repaired, re-certified or replaced by the Entrant at the Entrant's cost prior to use.

17.1.6.1. Chassis, nose and attenuator structural repairs may only be made by Dallara.

17.1.6.2. Chassis-repair forms must be submitted to INDYCAR for approval prior to the Car participating in the next Event.

17.1.6.3. After a crash, an Entrant must present the following items and any others to INDYCAR, upon request

- a) Driver's Helmet
- b) Driver's Head Restraint System
- c) Driver's Seat
- d) Chassis Headrest
- e) Steering Wheel
- f) Earpieces

17.1.7. Seating System

17.1.7.1. Each seat must be manufactured for a specific Driver. Each seat must have a unique identification tag from the seat manufacturer including Driver name, manufacturer name, and date of manufacture. All seats must be inspected and approved by INDYCAR before use and will be subject to re-inspection by INDYCAR at any time. INDYCAR may require a seat to be replaced.

17.1.7.2. The Driver's seat must conform to the Driver's anatomy, including the appropriate lumbar curvature and be constructed of an INDYCAR-approved material that will permit support and energy-attenuation both laterally and rearward. This material must fill as much of the cockpit under, behind and to the side of the Driver as possible. The seating system must be in place when the Car is inspected.

17.1.7.3. When the Driver is seated, there must be a smooth transition of energy-attenuating materials between the top of the seat and the cockpit rim padding, including the rear headrest. There must be no projections that could provide a fulcrum between the Driver's head and neck. Approved seating materials.

17.1.7.3.1. EPP foam provided by and manufactured by Bald Spot Sports.

17.1.7.3.1.1. EPP seats will be impounded and inspected following an incident where the recorded chassis G forces meet or exceed (65) Gs and may be returned

17.1.7.3.2. Creafoam kit provided by Bald Spot Sports and manufactured by an approved builder

17.1.7.3.2.1. Creafoam seats will be impounded following an incident where the recorded chassis G forces meet or exceed (65) Gs and will not be returned.

17.1.7.3.3. Driver side of the seat must be covered in a fire-retardant material.

17.1.8. Seat Belts - An approved seat belt with an approved quick-release mechanism must be used. Both the fastening design and condition of the belt are subject to inspection by INDYCAR. The life of the belts in use shall not exceed five (5) years for FIA-approved belts and two (2) years for SFI-approved belts. All six (6) belts must be individually date stamped by the manufacturer. All belts must conform to the following SFI specifications: 16.5/16.7 or FIA 8853-2016 (6-point only), or equivalent specification as approved by INDYCAR.

17.1.8.1. Seat belts must be worn in such a manner that they are tight and pass around the pelvis at a point below the anterior superior iliac spine.

17.1.8.2. Seat belts may not pass over the sides of the seat. They must come through the seat at the bottom on each side thereby wrapping and holding the pelvis over the greatest possible area.

17.1.8.3. 6-point (crotch) belts must be connected to the main belt quick-release mechanism and securely attached to the chassis.

- 17.1.8.4. Seat belts which have had to withstand a crash in excess of sixty-five (65) Gs in any axis must be replaced.
- 17.1.8.5. Only the Dallara shoulder belt brackets and associated hardware may be used as supplied without modification.
- 17.1.8.6. Only the Dallara Lap Belt Mounting Plates and associated hardware may be used as supplied without modification.
- 17.1.8.7. Only the Dallara-recommended Anti-Submarine belts' mounting hardware may be used as supplied without modification.
- 17.1.9. Shoulder Harness – Two (2) over-the-shoulder straps constructed of polyester yarns must be used. HANS® specific double-shoulder belts are also permitted provided they are mounted and used according to manufacturer specifications. Both the fastening design and condition of the straps is subject to inspection by INDYCAR. Life of the straps in use shall not exceed five (5) years and must be date-stamped by the manufacturer. Belts should be attached level with the top of the Driver's shoulders or at a slightly downward angle.
 - 17.1.9.1. Mounting of all belts must use the manufacturer supplied mount and use the supplied mounting positions unless otherwise approved by INDYCAR.
- 17.1.10. Headrests - Headrest must be used as supplied by Dallara. Headrests may only be covered with decal material.
 - 17.1.10.1. All headrests must be inspected and approved by INDYCAR before use and will be subject to confiscation and re-inspection by Officials at any time. INDYCAR shall affix stickers to the headrests signifying approval for use. At any time, Officials may remove the approval stickers and require the headrests to be re-inspected and refurbished by Dallara before INDYCAR may consider them for re-approval.
 - 17.1.10.2. Headrests must be attached by the Dallara supplied mechanism. The headrest must be in place during technical inspection.
- 17.1.11. Additional Headrest Padding – Additional side padding must not exceed the height of the stock headrest as viewed from the side. Additional rear padding must not exceed the height or width of the headrest as viewed from the front. All padding must be contained in the original headrest dimensions as looked at in plan view.
 - 17.1.11.1. The additional headrest padding, if used, must consist of separate pieces; left side, right side and/or rear. The side pieces are restricted to 15.000 inches in overall length, measured from the headrest's rear-to-side radius and must have a minimum 3.000-inch leading edge taper from the front edge when viewed from the top (plan view).
 - 17.1.11.2. The additional padding must be removable independently of each other without the use of tools. All additional padding must be manufactured completely of foam, each piece may have a single layer Kevlar backing to assist in the mounting providing that it remains flexible and does not interfere with the original function of the stock headrest.
 - 17.1.11.3. Any covering used on the additional padding must remain flexible and be approved by INDYCAR.
 - 17.1.11.4. Additional padding may not be taped along any surface. All additional pads and coverings must be inspected and approved by INDYCAR prior to use.
- 17.1.12. Roll Hoop – The Drivers helmet must be a minimum of 5.000 inches below the chassis mounting face of the roll hoop camera.
- 17.1.13. Cockpit – Cars must have fitted all the Dallara supplied cockpit panels and EPP foam panels in the seat area. Minimal trimming for installation is permitted, provided the panels retain their ability to properly absorb energy.
- 17.1.14. Only the following steering wheel quick disconnect is approved:

	Manufacturer	Description	Part Number
Steering Wheel Quick Disconnect	SPA	SPA tight tolerance Quick Disconnect	QR2
	MPI	MPI Quick Release	MPI-QR-RX-03

- 17.1.15. On-Board Fire Equipment – Each Car must have the INDYCAR-approved on-board fire suppression system conforming to SFI Specification 17.2. The system must be installed in the Dallara/INDYCAR specified location with the Dallara-supplied mounting system.
 - 17.1.15.1. AFFF 5 lb. bottle and nozzles
 - 17.1.15.2. 3M Novec 1230 3lb bottle and nozzles (mandatory for 2024 season).
- 17.1.16. Impact Recorders – All Cars must make provisions for the installation of an impact recorder.
 - 17.1.16.1. The impact recorder supplied by INDYCAR and used without modification, must be securely bolted using four (4) bolts to the main chassis structure in the Dallara/INDYCAR specified location.
 - 17.1.16.2. The impact recorder download block and indicator lights must be located in the Dallara/INDYCAR specified location.
- 17.1.17. Crew Members, Other Competitors and Officials - Except as provided in Rule 18.1.5.1 and Rule 18.1.17 all Competitors and Officials on the trackside of Pit Lane must adhere to the following dress code:
 - a) Long pants;

- b) Closed-toe shoes
- c) Shirts with sleeves (no tank tops); and

17.1.17.1. Only crew members, suppliers vested photographers and officials are permitted on the hot side of physical pit wall.

17.1.17.1.1. INDYCAR and/or an Event Promoter may have additional or different requirements for a particular Event.

17.1.18. Engine Start

17.1.18.1. Road/Street Courses – On-track and Pit Lane Engine Start Procedure.

17.1.18.1.1. When track safety personnel are not in attendance at the Car, Engine Start is permitted at any time.

17.1.18.1.2. When track safety personnel are in attendance at the Car, and subject to a Driver's obligations under Rule 7.1.3, the Driver must strictly adhere to all direction including hand signals and verbal instructions which include but are not limited to; Engine Start/Stop, Driver egress from Car, Car movement per Rule 17.1.18.1.4, relinquishing controls to track safety personnel, and/or care direction. Acknowledgment and clearance shall be made directly between the Driver and the on-scene track safety personnel on the ground.

17.1.18.1.3. For purposes of this Rule, track safety personnel shall be deemed "in attendance" when one or more track safety personnel are on foot in the immediate vicinity of the Car.

17.1.18.1.4. Following an Engine Start, the Driver must not cause the Car to move until the on-scene track safety personnel has cleared the Car to proceed.

17.1.18.1.5. Not permitted on track at Ovals any time.

18. GLOSSARY

- **ACCUS-FIA** – The Automobile Competition Committee of the United States is the ASN of FIA for the United States. ACCUS is comprised of the six (6) major motorsports sanctioning organizations (known by or within the FIA as "member clubs"): IMSA, INDYCAR, NASCAR, NHRA, SCCA and USAC. In accordance with the FIA statutes and the international sporting code, ACCUS-FIA has delegated its sporting power to the member clubs, except for FIA World Championship events.
- **Aero Kit** – All the components of the Car identified by INDYCAR, supplied by an Approved Supplier, approved by INDYCAR and governed by these Rules for all circuit configurations.
- **Approved Supplier** – A supplier (including Manufacturers) of components that has been approved by INDYCAR, in its sole and absolute discretion.
- **ASN** – The National Sporting Authority of the FIA is a national automobile club or other national body recognized by the FIA as sole holder of sporting power in a country, except that in accordance with the FIA statutes and the international sporting code, an ASN may delegate some or all of its sporting power to its member clubs. An ASN is the liaison between its member clubs, other ASNs and the FIA. An ASN prepares listings on the international calendar, issues international motorsport licenses to its citizens and foreign citizens living in the country, issues authorizations for foreign participation and certifies and maintains domestic and international records.
- **Associate** – The firm(s), corporation(s) or other business association(s) named on an Associate's membership application approved by INDYCAR, remaining in Good Standing and uniquely identified by a tax identification number. Associate includes Associate and Associate's officers, directors, members, owners, successors, assigns, agents, employees, representatives and affiliates. Associate includes Manufacturers. Associate is responsible for Associate Group.
- **Associate Group** – Associate Participant, Associate Guest and each third-party Associate represents. "Associate Participant" is defined as any individual who is a Participant by reason of his or her relationship to Associate. "Associate Guest" is defined as any individual whose presence at a Track is at the invitation of the Associate.
- **Backup Car** – A spare Car an Entrant may use on-Track in place of a primary Car if approved by INDYCAR.
- **Blend Line** – The time line that decides the sequential order of Cars on-Track relative to Cars exiting Pit Lane under a Yellow Condition.
- **Business Day** – Any day other than a Saturday, Sunday or other day on which commercial banks are authorized to close under the laws of, or are in fact closed in, the state of Indiana.
- **Car** – A four (4) wheel automotive vehicle consisting of the combination of Aero Kit, Chassis, Engine, gearbox and Tires. The vehicle must be supplied by Manufacturers or Approved Suppliers, approved by INDYCAR and conform to the specifications, spirit and illustrations in and intent of the Rules.
- **Competitor** – A Driver, Entrant, crew member, Manufacturer or any other individual or entity who is a Member and participates competitively in an Event.
- **Firestone** – Bridgestone Americas Tire Operations, LLC, is the approved Tire manufacturer. Any reference in the Rules to "Firestone" is referring to Bridgestone Americas Tire Operations, LLC.
- **Cosworth** – Cosworth, LLC, an approved electronic supplier. Any reference in the Rules to "Cosworth" is referring to Cosworth, LLC.
- **Current INDY NXT by Firestone Driver** – A Driver that has participated in the current or the previous INDY NXT by Firestone season and/or approved by INDYCAR.
- **Dallara** – Dallara, LLC, the approved chassis manufacturer. Any reference in the Rules to "Dallara" is referring to Dallara, LLC.
- **Day** – The twenty-four (24) hour period within a single calendar day.
- **Discretion** – The exercise by INDYCAR of judgment in making a determination as to the application, construction and interpretation of the Rules; and is required because of the need for decisions that depend upon immediacy without reflection and/or that are often subjective.
- **Double-Header Race Location** – A Race Location where more than one Race is held. Double-Header Race Location does not include the Indianapolis Motor Speedway.
- **Driver** – The individual named on a Driver's License and membership application approved by INDYCAR and issued by ACCUS-FIA (or another ASN, if applicable) and remaining in Good Standing. Driver is responsible for Driver Group.
- **Driver Group** – Driver Guest and each third-party Driver represents. The term "Driver Guest" shall mean and include any individual whose presence at an Event is at the Driver's invitation.
- **ECU** – The INDYCAR approved and supplied engine control unit (ECU), which is the primary device responsible for the control, monitoring and data logging of all Engine induction, fuel and turbo charger control sub-systems.
- **Engine** – An engine supplied by the engine Manufacturer or their designees, approved by INDYCAR and conforming to the specifications, spirit and illustrations in and intent of the Rules.
- **Entrant** – The firm(s), corporation, or other business association(s) named on an Entrant's License and membership application approved by INDYCAR and issued by ACCUS-FIA, remaining in Good Standing and uniquely identified by a tax identification number and Car number. Entrant includes Entrant and Entrant's officers, directors, members, owners, successors, assigns, agents, employees, representatives and affiliates. Entrant is responsible for Entrant Group.
- **Entrant Group** – Entrant Participant, Entrant Guest and each third-party Entrant represents. "Entrant Participant" is defined as any individual who is a Participant by reason of his or her relationship to Entrant. "Entrant Guest" is defined as any individual whose presence at a Track is at the invitation of the Entrant.

- **Entry** – An Entrant's Car and Driver combination on an Entry form displaying the Entrant's Car number and approved by INDYCAR for participation in a designated on-Track Event.
- **Event** – Any racing, promotional and/or entertainment or other activities associated with, sanctioned by and/or organized in cooperation with INDYCAR or occurring at the site of, contemporaneously with or reasonably connected to said activities.
- **Event Agreement** – The agreement in effect between INDYCAR and an Event Promoter regarding the conduct of an Event and/or Events.
- **Event Promoter** – The firm(s), corporation(s) or other business association(s) named on an Event Agreement with INDYCAR and responsible for designated operations of an Event. Event Promoter includes Event Promoter and Event Promoter's officers, directors, members, owners, successors, assigns, agents, employees, representatives and affiliates.
- **FIA** – The Federation Internationale de l'Automobile.
- **Full-Season** – Scheduled to participate in every Race.
- **Good Standing** – INDYCAR decides good standing of an individual and/or entity by a review of:
 - Financial and/or legal status with respect to INDYCAR and Manufacturers, and
 - Such other factors as INDYCAR deems relevant to the decision.
- **Grid** – The physical location where the Cars are positioned in Starting Lineup order prior to the start of a Race.
- **Guaranteed Attempt** – A Car's opportunity to present itself for the Qualifications process.
- **Headings** – The subject headings are included for purposes of convenience only and shall not affect the construction or interpretation of any of the Rules.
- **Homologated** – INDYCAR approved design and location of a component for use at an Event.
- **INDYCAR** – INDYCAR, LLC, the member club of ACCUS; the owner and operator of the INDY NXT by Firestone series; the owner of the INDY NXT by Firestone series; and the sanctioning body for the INDY NXT by Firestone series, INDY NXT by Firestone series, Indy Pro 2000 Championship and USF2000 Championship. INDYCAR includes INDYCAR and INDYCAR's officials, officers, directors, members, owners, successors, assigns, agents, employees, representative and affiliates. "INDYCAR" and "Leaders Circle" are registered trademarks with the United States Patent and Trademark Office and cannot be used without authority from INDYCAR or Brickyard Trademarks, Inc. Any reference in the Rules to "INDYCAR" is referring to INDYCAR, LLC.
- **INDYCAR Group** – INDYCAR, FIA, ACCUS-FIA, Event Promoters, other Members and the officers, directors, employees, agents, affiliates, representatives, owners, successors and assigns of each of them.
- **IOB** – The Board of Directors of INDYCAR Officiating Incorporated.
- **IOI** – INDYCAR Officiating Incorporated. The non-profit governance entity charged primarily with the application, enforcement and interpretation of Sporting, Technical, Safety, and Aero Kit Regulations.
- **IRIS** – INDYCAR Information System is the official online communication platform for Competitors.
- **Lapped Car** – A Car that is at least one lap behind all Cars that are on the Race leader's lap.
- **License** – An authorization approved by INDYCAR and issued by ACCUS-FIA (or another ASN, if applicable) to an individual or entity to participate in a Race as a Driver, Entrant or Official.
- **Manufacturer** – The firm(s), corporation(s) or other business association(s) named on an Associate's membership application approved by INDYCAR, remaining in good standing and uniquely identified by a tax identification number. Manufacturer includes the approved chassis, Tire, Engine and gearbox Manufacturers and their officers, directors, members, owners, successors, assigns, agents, employees, representatives and affiliates.
- **Member** – An individual, firm, corporation or other business association entity named on an annual membership application, approved by INDYCAR and remaining in good standing. Without limitation, each Competitor and Official must be a Member. Member is responsible for Member Group.
- **Member Group** – Member Guests, Member Participants, and each third-party Member represents. The term "Member Guest" shall mean and include any individual whose presence at an Event is at Member's invitation. The term "Member Participant" shall mean and include any individual who is a Participant by reason of his or her relationship to Member.
- **Non-Qualified Car** – A Car not successfully completing Qualifications. A Non-Qualified Car may be approved by INDYCAR to participate in a limited manner in a Race.
- **INDY NXT by Firestone** – The INDYCAR Series owned, operated and sanctioned by INDYCAR. INDYCAR includes INDYCAR and INDYCAR's officials, officers, directors, members, owners, successors, assigns, agents, employees, representative and affiliates. INDY NXT by Firestone (and design) are registered trademarks of Brickyard Trademarks, Inc., used with permission. Any reference in the Rules to the INDY NXT by Firestone may include INDYCAR and any reference to INDYCAR may include a reference to the INDY NXT by Firestone if the context so requires.
- **Officials** – Any and all authorized INDYCAR and IOI officers, employees, agents, representatives and subcontractors. Officials specifically referenced in the Rules include:
 - "Chief Executive Officer", Mark Miles
 - "President", J. Douglas Boles
 - "Sr. VP of Competition and Operations", Mark Sibla
 - "VP of Officiating and Race Director", Kyle Novak
 - "Medical Director", Julia Vaizer, MD
 - "Medical Review Officer", Douglas Aukerman, MD
 - "Race Stewards", Arie Luyendyk and Max Papis

INDYCAR and/or IOI may replace any Official with another Official(s) at any time. The above-named Officials may delegate their authority in whole or in part to another Official(s) at any time. INDYCAR may replace any Official with another Official(s) at any time. The above-named Officials may delegate their authority in whole or in part to another Official(s) at any time.

- **Open Test** – A Open Test is a period of on-Track activity to: i) promote the Race at the Race Location and ii) to prepare Participants for the Race and for other Races at other venues.
- **Oval/Oval Events** – A Race Location where all on-Track turns are left-handed.
- **Pace Car** – An official Pace Car approved by INDYCAR, driven by an authorized individual and used during on-Track activities.
- **Partial Season Entrant** – An Entrant in one or more, but not all, of the Races during the Racing Season.
- **Participant** – Any individual or entity along with their officers, directors, members, owners, successors, assigns, agents, employees, representatives and affiliates that are in any way associated or connected with Track premises, Testing facilities or other INDYCAR-approved locations or Event including, without limitation, facility owners, Event Promoters, municipalities, racing associations, sanctioning organizations, series organizers, Officials, workers, volunteers, Entrants, Car owners, Drivers, pit crew members, safety crew members, medical/rescue personnel, sponsors, Manufacturers, suppliers, designers, advertisers, inspectors, construction contractors, engineers, architects, insurers and all individuals in a restricted area.
- **Penalty Guidelines** – The penalty issued for a violation of each Sporting Regulation of the Rules during Qualifications and Races and designated other Rules is taken from the Penalty Guidelines. The Penalty Guidelines have been developed by INDYCAR with input from the Race Stewards, Drivers and Entrants, and they shall contain a violation, Rule reference (Rule number and a brief description of the rule), as well as the minimum, mid, and maximum penalty for violation of the Rule.
- **Pit Box** – The area of the Pit Lane specified to an Entrant for service of a Car including refueling, tire changes, and repairs. This area includes both sides of the Pit Wall.
- **Pit Commitment Line** – The time line that decides if a Car is within the Pit Lane boundaries at the time of a Yellow Condition.
- **Pit Entry/Exit Lane** – The lane in Pit Lane closest to the Pit Boxes.
- **Pit Lane** – The part of the Track that leads from the Racing Surface to the Pit Boxes or from the Pit Boxes back to the Racing Surface. It has specified starting and ending points and is defined by painted lines, cones and/or other visible markings.
- **Pit Out Commit Line** – The time line that decides if a Car has followed proper procedures exiting Pit Lane. At some Tracks, the Pit Out Commit Line is the same line as the Blend Line.
- **Pole Position** – The first (1st) position in the Starting Lineup.
- **Primary Car** – The first Car presented at technical inspection
- **Provisional Starting Car** – An Entrant who is granted permission to start a Race based on previous championships, current points or other means as determined by INDYCAR or the Indianapolis Motor Speedway, as applicable.
- **Push to Pass** – A system controlled by the ECU that allows for the Engine power to be increased for a period of time when activated by a button press by the Driver.
- **Qualifications** – The process to determine the eligibility and starting position of each Car desiring to participate in a Race by ranking the Car on the basis of its performance in Qualifications.
- **Qualified Car** – A Car that successfully completes Qualifications.
- **Race** – The INDY NXT by Firestone race(s) occurring at an Event for which points are awarded.
- **Race Location** – A location where on-Track activities take place.
- **Race Procedure** – Is the manner in which an Event is conducted. It includes, but is not limited to, At Track Procedures described in [Rule 7](#) (On-Track Conditions, Flag Codes and Track condition lights, Timing and Scoring, Pit Boxes, Race Start, Race Restart, Mechanical Conditions, Performance Standards, Pit Procedures, Pit Safety Violations) and Qualifications described in [Rule 8](#).
- **Race Stewards** – The Race Stewards (individually referred to as a Race Steward) are Officials stationed in race control who shall determine on-track violations of the Sporting Regulations of the Rules during Qualifications and Races. The IOB shall select the Race Stewards. Unless otherwise notified, the same individuals shall serve as Race Stewards during every Event. All Race Stewards shall report to the IOB. The IOB will expect and be the sole judge that each Race Steward is unbiased, fair, honest, ethical, and consistent and has comprehensive knowledge of the Sporting Regulations of the Rules and racing as established by these Rules and the interpretations and determinations of the IOB. The IOB may remove any Race Steward at any time if deemed such Race Steward is unsuitable or has a conflict. The Race Stewards shall: i) attend the pre-Race Drivers' meetings scheduled by INDYCAR to provide updates to Competitors on the Sporting Regulations of the Rules generally applicable to NTT INDYCAR SERIES Qualifications and Races and any Sporting Regulations of the Rules specifically applicable to Qualifications and Race; and ii) be available for one (1) hour post-Race and post-Qualifications at the INDYCAR Administration Trailer to review Race and/or Qualifications decisions with Competitors
- **Racing Season** – All Open Tests and Race Events beginning with the first Race or first Open Test, whichever occurs earlier, and continuing through the final Race.
- **Racing Surface** – The area designated by INDYCAR as eligible for use during competition. It may be formed by boundaries such as a wall or a line. It does not include grass or runoff areas.
- **Registration** – The unique identity number assigned to a specific Car by Dallara.
- **Restarting Lineup** – The order of Cars on-Track for the restart of a Race.
- **Road Course Event** – A purpose-built permanent Track where turns are left and right-handed.

- **Rookie Driver** – A Driver is a Rookie Driver in the INDY NXT by Firestone series if the Driver has i) not participated in more than four (4) INDY NXT by Firestone Races in a Racing Season or ii) participated in less than eight (8) INDY NXT by Firestone Races in his/her career.
- **ROP** – Rookie Orientation Program. A Test, supervised by INDYCAR to demonstrate Car control, placement and a consistent driving pattern by a Rookie Driver.
- **Rules** – This INDY NXT by Firestone Rule Book, including without limitation, Aero Kit Regulations, Engine Regulations, supplementary guidelines, Substance Abuse Policy, Social Media Policy, Style Guide, Penalty Guidelines and bulletins issued by Officials, whether containing Rules applicable only to a particular Event(s) or containing Rules of general applicability. The most current version is available at <http://epaddock.indycar.com/rulebook>. Notwithstanding the foregoing, Rules may be issued verbally in mandatory meetings such as Drivers meetings held during Events.
- **Season Start** – A designated date or the first Open Test or the first on-Track day of the first Race of a given calendar year, whichever comes first.
- **Short Oval Events** – An Oval/Oval Event with a Track distance of 1.4 miles or less.
- **Single Race Event Entrant** – An Entrant whose participation is scheduled for only one Event at a time, even if participating in consecutive Events.
- **Speedway/Superspeedway Events** – An Oval/Oval Event with a Track distance greater than 1.4 miles.
- **Sporting Regulations** – Sporting Regulations are the Race Procedures of the Rules including, but are not limited to, on-Track competition such as blocking, contact, restart violations, Pit Lane infractions, Qualifications interference, local yellow performance reduction expectation, Track boundary infraction, packing up under Yellow Condition or failing to pace; however, it does not include technical, operations or off Track competition such as Engine Regulations, Aero Kit Regulations, and Substance Abuse Policy violations. The Race Stewards shall determine violations of the Sporting Regulations of the Rules during Qualifications and Races.
- **Start/Finish Line** – The areas of a Track specified by INDYCAR to decide the start, lap completion, and/or completion of an on-Track activity. If applicable, it may extend across and include Pit Lane.
- **Starting Lineup** – The order of Cars on-Track for the start of a Race.
- **Steward** – An individual designated by the President of INDYCAR to have specific authority to assist with the application, construction, interpretation and enforcement of the Rules.
- **Steward's Review** – The request from a Race Steward and/or the Race Director during Qualifications and/or a Race for review of an incident as a potential violation of the Sporting Regulations of the Rules for issuance of a penalty.
- **Street Course Event** – A purpose-built temporary Track where turns are left and right-handed.
- **Team** – One or more Entrants under common ownership and/or control as determined by INDYCAR.
- **Test** – Any period during which a Member conducts any Testing.
- **Testing** – The use of the approved chassis, Engine, Aero Kit, gearbox and Tires, separately or in any combination during a period other than practice, Qualifications or a Race.
- **Tire(s)** – Tires supplied by Firestone, approved by INDYCAR, and governed by these Rules.
- **Presenting Sponsor** – Firestone its affiliates and the successors, assigns, officer, directors, owners, members and representatives and employees of each of them.
- **Track** – The area including without limitation the Racing Surface, pit entrance lanes, Pit Lane and pit exit lanes located between the outer and innermost retaining walls.
- **Track Condition** – The status under which on-Track activity is conducted.
- **Use** – This is defined as being propelled under power generated by the Engine.